

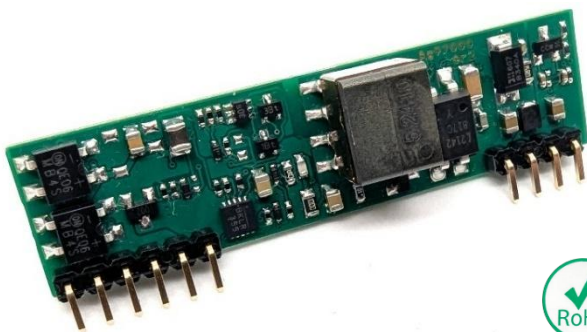

Ag97000

Low Cost 12W Power-over-Ethernet Module



CODICO GmbH

Zwingenstraße 6-8, 2380 Perchtoldsdorf, Austria
 Telefon: +43 1 86 305-0, Fax: +43 1 86 305-5000
 e-mail: office@codico.com, www.codico.com
 FN 436940i, Landesgericht Wr. Neustadt

Zertifiziert nach ISO 9001:2015



Features

- Optimised for low cost
- Efficient 12W DC/DC converter
- Programmable classification request
- IEEE802.3 class 0 PD (PoE) for up to 12W output applications
- 5V, 12V and 24V variants available
- Integrated bridge rectifier
- Integrated output filter for low output ripple & noise
- Robust overload, short-circuit and thermal protection
- Adjustable output voltage
- Industrial temperature range
- Minimal external components required
- Small Single in line (SIL) package 56mm x 14mm x 13mm
- 1500Vdc isolation (input to output)
- Silvertel “design-in” assistance
- Designed and manufactured in the UK

Description

The Ag97000 series Power-over-Ethernet (PoE) modules are designed to extract power from a conventional twisted pair Category 5 or higher Ethernet cable, conforming to the IEEE802.3 PoE standard, with full compatibility with the IEEE802.3bt, IEEE802.3at and IEEE802.3af amendments.

The Ag97000 is pre-configured as a Type 1 Class 0 device, requesting 15.4W of power from the PSE, with nominal output voltages of 5V, 12V or 24V. Additionally, the module can be programmed to request Class 1, Class 2, or Class 3 power levels with the fitment of an external resistor.

The DC/DC converter can achieve efficiencies up to 89% efficiency and operates over a wide input voltage range with a low ripple and low noise output. The DC/DC converter also has built-in output overload, output short-circuit and over-temperature protection and provides a 1500Vdc (input to output) isolation barrier.

Table of Contents

1	Product Overview	3
1.1	Ag97000 Product Selector	3
1.2	Package Format	4
1.3	Pin Description	4
1.4	Typical Connections	5
2	Input	5
2.1	DC/DC Power On/Off Hysteresis	5
2.2	PD Signature	6
2.3	Power Classification	6
2.3.1	Power Classification Programming	6
3	Output	7
3.1	Maximum output power	7
3.2	Output Voltage Adjust Setting	7
3.3	Output Capacitance	8
3.4	Output Filtering	8
3.5	Maintain Power Signature	8
4	Operating Temperature Range	9
4.1	Thermal Considerations	9
5	Protection	10
5.1	Input Protection	10
5.2	Output Back Feed Protection	10
5.3	Output Short Circuit Protection	10
5.4	Thermal Protection	10
6	Isolation	11
7	EMC	11
8	Solderability	12
9	Electrical Characteristics	12
9.1	Absolute Maximum Ratings	12
9.2	Recommended Operating Conditions	12
9.3	DC Electrical Characteristics	13
10	Package	14
11	Packaging	15
12	Ordering Code	15

Table of Figures

Figure 1:	Block Diagram	3
Figure 2:	Ag97000 Package Format	4
Figure 3:	Typical System Diagram	5
Figure 4:	Class Programming Option	6
Figure 5:	Output Voltage Adjustment	7
Figure 6:	Output Filter	8
Figure 7:	Input Protection	10
Figure 8:	Typical Connection Diagram	11
Figure 9:	Package Dimensions	14
Figure 10:	Land Pattern	14

1 Product Overview

1.1 Ag97000 Product Selector

Part Number ¹	Nominal Output Voltage	Output Power	Marking ²	Package
Ag97005-FL	5V	12W Continuous	ab05FL	SIL
Ag97012-FL	12V		ab12FL	
Ag97024-FL	24V		ab24FL	

Note 1: Complies with the European Directive 2011/65/EU for the Restriction of use of certain Hazardous Substances (RoHS) including Directive 2015/863 published in 2015, amending Annex II of Directive 2011/65/EU. Moisture Sensitive Level 1 and HBM 1.

Note 2: Located on the transformer.

The first letter, a, indicates the week as A-Z with uppercase being weeks 1-26, lower case weeks 27-52.

The second letter, b, indicates the year in uppercase A-Z starting from 2020.

The two digits are the nominal output voltage,

The final letters, are the model variant.

Table 1: Ordering Information

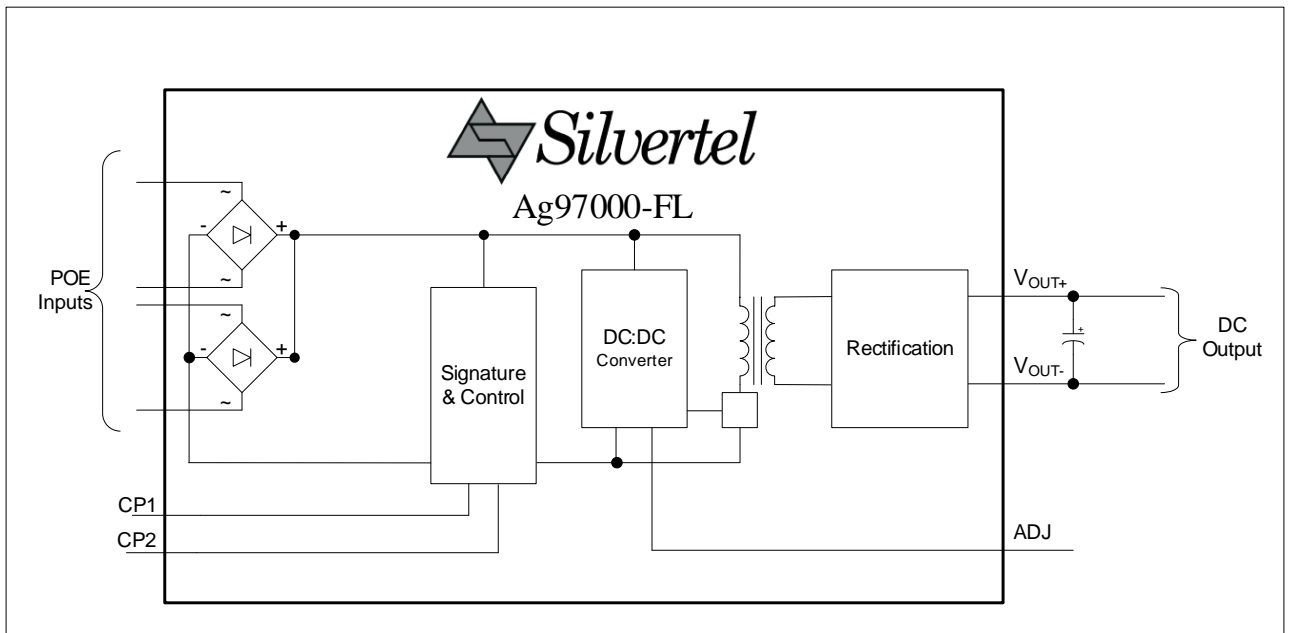

Figure 1: Block Diagram

1.2 Package Format

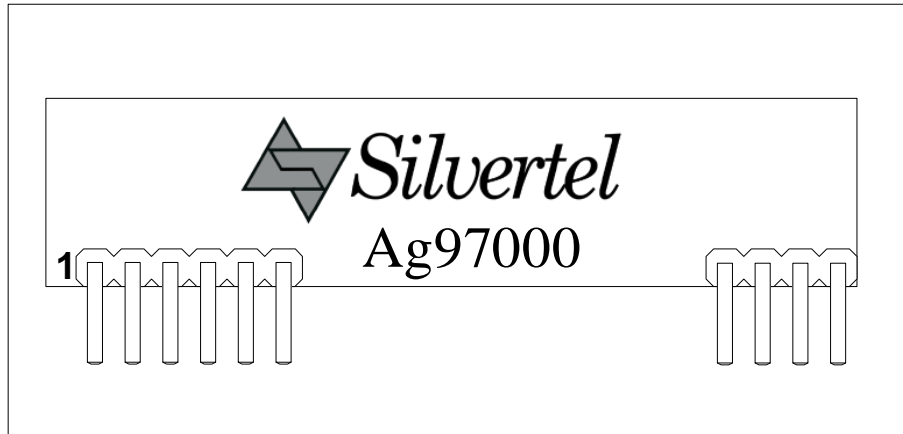

Figure 2: Ag97000 Package Format

1.3 Pin Description

Pin #	Name	Description
1	V _{INA}	POE Direct Input . These pins connect the internal bridge rectifiers to the centre taps of the Data transformer, these pins are not polarity sensitive
2	V _{INB}	
3	V _{INC}	
4	V _{IND}	
5	CP1	Class Programming (1) . Connecting an external resistor between this pin and CP2 will change the current class of the module (see section 2.3.1). When not connected, the Ag97000-FL will default to Class 0.
6	CP2	Class Programming (2) . Connecting an external resistor between this pin and CP1 will change the current class of the module (see section 2.3.1). When not connected, the Ag97000-FL will default to Class 0.
7	V _{OUT-}	Negative DC Output . This pin provides the negative regulated output from the Ag97000-FL.
8	V _{OUT+}	Positive DC Output . This pin provides the positive regulated output from the Ag97000-FL.
9	ADJ	Output Adjust . The output voltage can be adjusted from its nominal value, by connecting an external resistor from this pin to either the V _{OUT+} pin or the V _{OUT-} pin.
10	IC	Internal Connection . Do not connect to this pin.

Table 2: Ag97000-FL Pin Description

1.4 Typical Connections

The Ag97000 requires few external components - The output capacitor (C1) connected across the output is required for correct operation of the DC/DC converter. This capacitor should be positioned as close to the output pins as possible for optimal stability. This can be a low-cost electrolytic capacitor, as shown in Figure 3; or the required capacitance can be built up using multiple multilayer-ceramic capacitors to achieve similar stability without the lifetime restrictions of an electrolytic capacitor, see section 3.3 for more details.

The output voltage can be adjusted by simply connecting a resistor between the ADJ pin and either the V_{OUT+} Pin or the V_{OUT-} pin, see section 3.2 for more details.

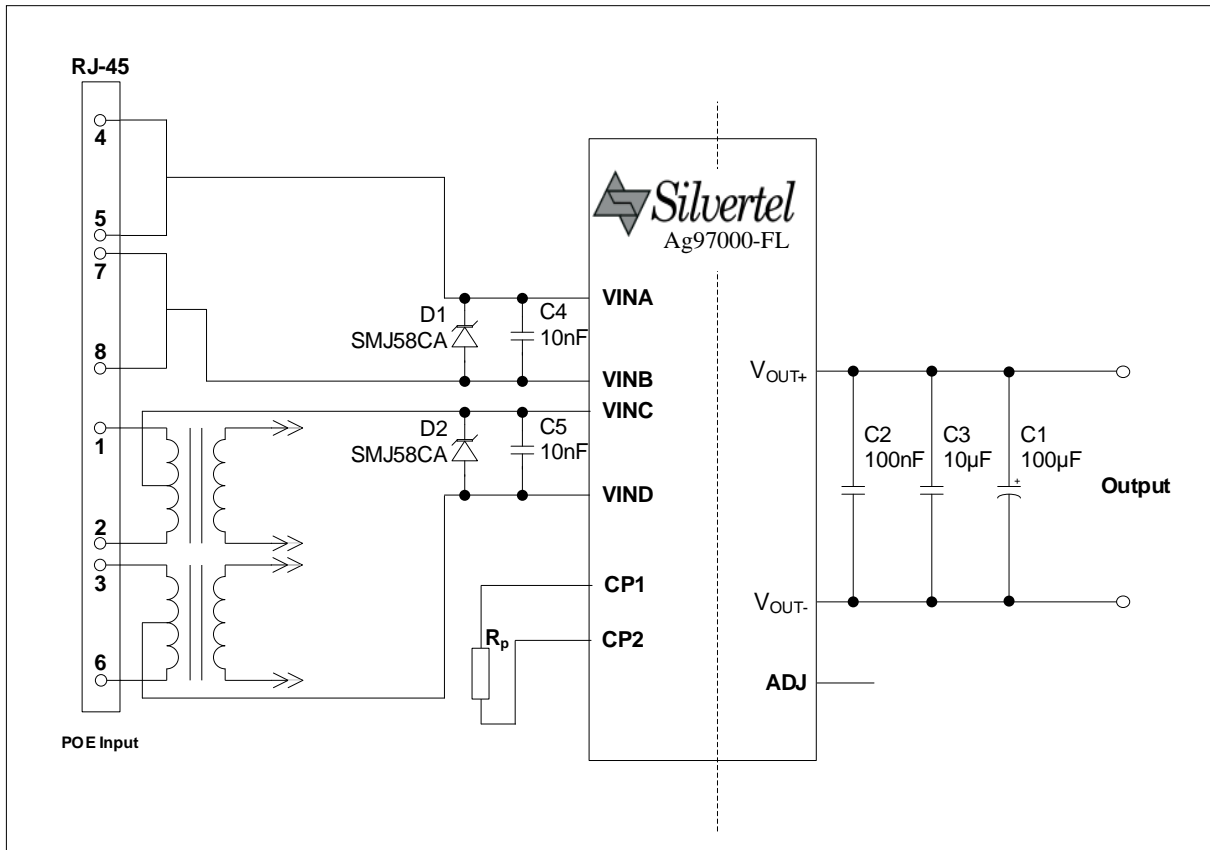

Figure 3: Typical System Diagram

2 Input

The Ag97000-FL has four input pins V_{INA} , V_{INB} , V_{INC} and V_{IND} , these pins should be connected to either the centre taps of the data transformer, or to the shorted conductors of an unused pair (see Figure 3: Typical System Diagram). This allows the Ag97000 to be compatible with Power Sourcing Equipment (PSE) devices that utilise any of the different power polarities permissible

The Ag97000 is designed to be powered by any compliant IEEE802.3 PSE, such as those utilising Silvertel's Ag6130 PSE module.

2.1 DC/DC Power On/Off Hysteresis

To prevent oscillation the DCDC converter contains hysteresis on output enable thresholds, Both the power on and the power off thresholds are positioned below the normal operating voltages of an IEEE802.3 complaint PSE. See section 9.2 for more details.

2.2 PD Signature

The Ag97000 complies with the IEEE802.3 specifications and contains the signature and control circuitry specified within. When the inputs are connected to a PSE, they will automatically present a valid Powered Device (PD) signature to the PSE (when requested). The power sourcing equipment will then recognise that a PD is connected to the pairset and begin supplying power to the device.

2.3 Power Classification

The Ag97000 is a Type 1 PD configured Class 0 by default, requesting 15.4W of power from a compliant IEEE802.3 PSE by providing the classification response shown in Table 3.

Requested Class	Class Pulse Count	Pulse 1&2 Classification Current (mA)	Pulse 3+ Classification Current (mA)	PSE Output Power (W)	Min. Available PD Power (W)	IEEE Spec. Amendment
0	1	<5	N/A	15.4	12.75	802.3af
1	1	10	N/A	4	3.84	
2	1	20	N/A	7	6.49	
3	1	30	N/A	15.4	12.75	
4	2 or 3	40	40	30	25.5	802.3at
5	4	40	<5	45	40	802.3bt
6	4	40	10	60	51	
7	5	40	20	75	62	
8	5	40	30	90	71.3	

Table 3: Classification Table

2.3.1 Power Classification Programming

This feature helps facilitate use of the optional power management features of multiport PSEs. The Ag97000 requests Class 0 power levels by default, this results in the PSE supplying 15.4 to 20 Watts of power, identical to a class 3 device.

If desired, the Ag97000 can present a class 1,2, or 3 Classification power level request by connecting a resistor between the CP1 and CP2 pins, see Figure 4. The full list of programming resistor values are shown in Table 4

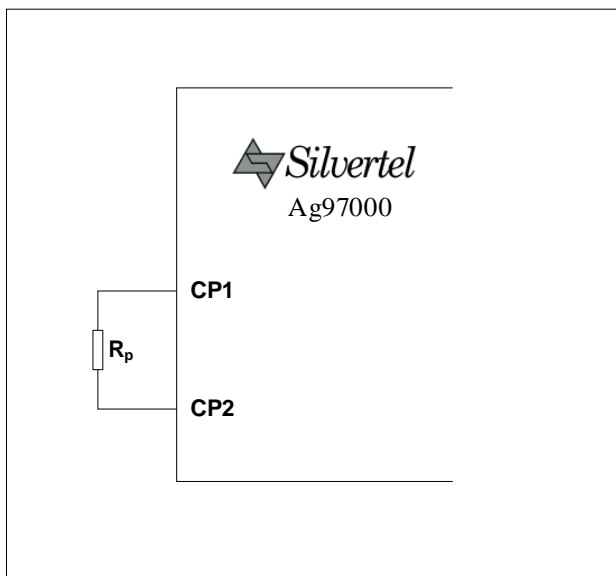

Figure 4: Class Programming Option

Class	Programming Resistance (Ohms)	Power Available (W)
0	Open Circuit	12.95
1	698 ±1%	3.84
2	383 ±1%	6.49
3	249 ±1%	12.75

Table 4: Class Programming

3 Output

3.1 Maximum output power

While the Ag97000-FL is capable of delivering a continuous output power of 12W to the application, the maximum output power may be limited by the available power at the input pins of the module.

Due to transmission losses, the minimum of 15.4W of power supplied by the PSE, may be reduced to 12.75W at the input to the RJ45. See "ANX-POE-Power" for more details. As a result, to ensure that the power budget is not exceeded across the range of installation parameters the application should be designed for a maximum continuous output power of 11W from the Ag97000.

3.2 Output Voltage Adjust Setting

The Ag97000-FL has an output voltage adjustment pin, ADJ, which can be used to either increase or decrease the output voltage of the module by connecting a resistor between the adjust pin and either V_{OUT-} or V_{OUT+} . For assistance selecting a suitable adjust resistor to achieve the desired output voltage please contact Silvertel.

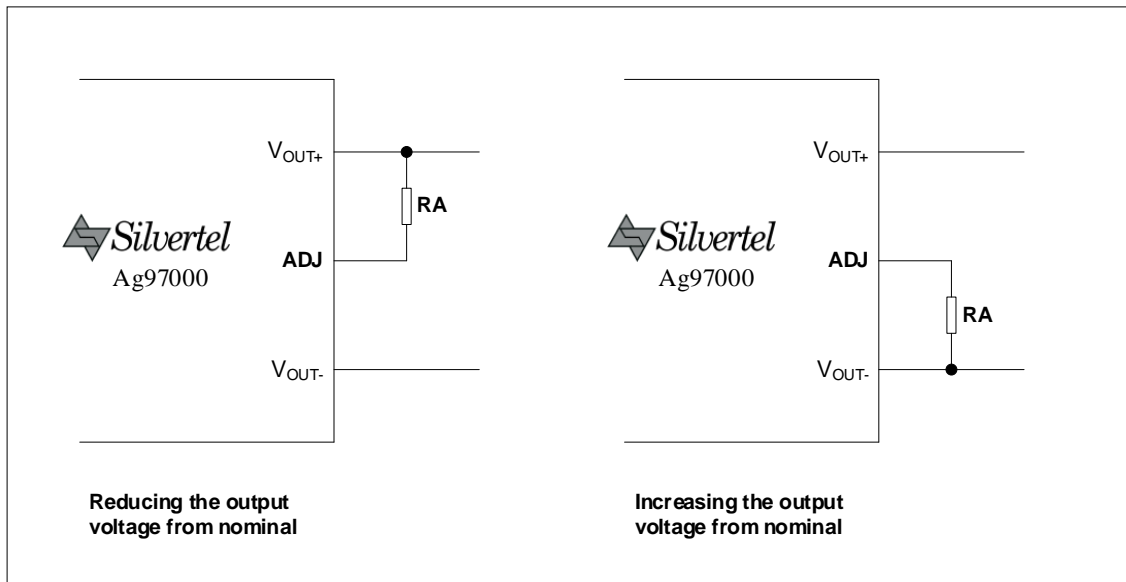

Figure 5: Output Voltage Adjustment

Reducing the output voltage, connect RA between ADJ and V_{out+}			
Value of RA	Ag97005	Ag97012 output	Ag97024 output
Open Circuit	5.0V	12.0V	24.0V
0 Ohms	4.45V	10V	19.5V
Increasing the output voltage, connect RA between ADJ and V_{out-}			
Value of RA	Ag97005	Ag97012 output	Ag97024 output
Open Circuit	5.0V	12.0V	24.0V
0 Ohms	5.65V	12.65V	24.65V

Table 5: Output Voltage Adjustment Resistor Values

3.3 Output Capacitance

If multi-layer ceramic capacitors are the preferred option to provide the required bulk capacitance on the output, it is recommended that 1206 packages or larger are used, and a rated capacitance of at least 66 μ F is fitted.

Due to the startup power limitations of the IEEE802.3 specification, a 100 μ F capacitor is recommended on the output of the module. If a higher capacitance is fitted, the peak load on the module before it has reached the regulated output voltage should be limited to prevent potential compatibility issues because of the inrush currents during startup.

3.4 Output Filtering

The Ag97000 has a built-in PI filter but requires a bulk capacitance to be fitted on its output for stable operation, this is typically provided with just an electrolytic capacitor, this provides a high level of output regulation and low output ripple. The recommended output filtering is shown in Figure 6.

The output capacitance does not need to be a low ESR type for operation in temperatures above 0°C. But if ambient temperatures below 0°C are expected, a capacitor that retains a moderate ESR rating and the minimum capacitance is essential for operation. Polymer Aluminium Solid Electrolytic Capacitors are ideal for this requirement.

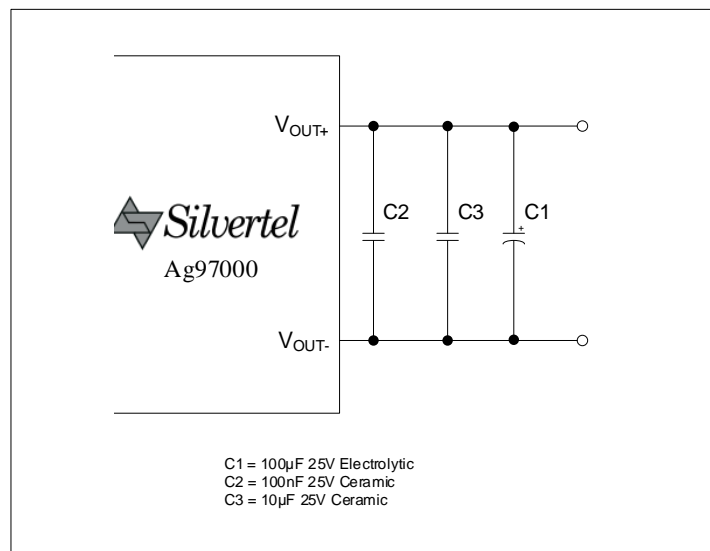

Figure 6: Output Filter

3.5 Maintain Power Signature

The Ag97000 does not require a minimum load for correct operation. However, when unloaded, the current draw from the PSE may not be high enough to satisfy the Maintain Power Signature (MPS) of the PSE, removing power from the link. The MPS requirement is stipulated in the IEEE802.3 specification to provide safety to the PoE system by ensuring power is not being sourced to an unconnected cable by monitoring the link to see if the PD has been disconnected.

If the applications load on the module drops below I_{OUT_MPS} in section 9.3 for a duration of time greater than 250ms (ignoring pulses less than 75ms in duration), then the PSE may determine that the device has been disconnected. Increasing the load for a sustained period of at least 75ms will reset the timer in the PSE, preventing a power removal event.

To reduce excess power dissipation, the load should be sized to increase the total loading of the module to meet the I_{OUT_MPS} current draw during these periods of low power draw. This load can be implemented in one of two methods; a static resistor connected across the modules output, this is the simplest method, but will increase the power draw of the application, even during the periods of highest power draw. Another method is to switch in a load only when required, this is more complex than a static resistor, but allows for power savings in low power applications, and does not reduce the maximum available power in applications that have high peak power draws.

4 Operating Temperature Range

At the heart of the Ag97000 is a DC/DC converter, it will generate heat. Whilst the product has been designed to be a high efficiency device, the small form factor requires that thermal management is taken into consideration at the design stage. The amount of heat generated by the module will depend on the load it is required to drive and the input voltage supplied by the PSE.

The Ag97000 can operate at full output power up to a maximum of 85°C ambient, and a minimum of -40°C ambient. When intended for used in ambient temperatures below 0°C it is recommended that an output capacitor that will retain the minimum output capacitance and ESR ratings for the Ag97000 at the lowest temperature in the intended operating range is used. A Polymer Aluminium Electrolytic Capacitor is ideal for this application, however a reputable brand rated to -55°C should suffice for most applications.

4.1 Thermal Considerations

Each application is different; therefore, it is impossible to give fixed and absolute thermal recommendations. However, it is important that any enclosure used has sufficient ventilation to remove power dissipated in the Ag97000 as well as that dissipated from the rest of the application circuitry. Forced airflow across the module is the preferred method of thermal management.

One simple method for drawing some of the thermal energy away from the module is by connecting power planes to the V_{out+} and V_{out-} pins of the Ag97000, these power planes must be on the outer layers of the PCB and the Ag97000 must not be fitted into a socket. The copper planes should be on the outer layers of the PCB, best results are achieved with additional copper planes on internal layers of host PCB with multiple thermal via connections. Further thermal management options are detailed in the application note "ANX-POE-Thermal-Considerations".

5 Protection

5.1 Input Protection

The Ag97000 may be damaged by input voltage transients greater than 80V, an over-voltage clamping device can be fitted across the input pins, see Figure 7 and Apps Note “ANX-POE-Protection” for more details.

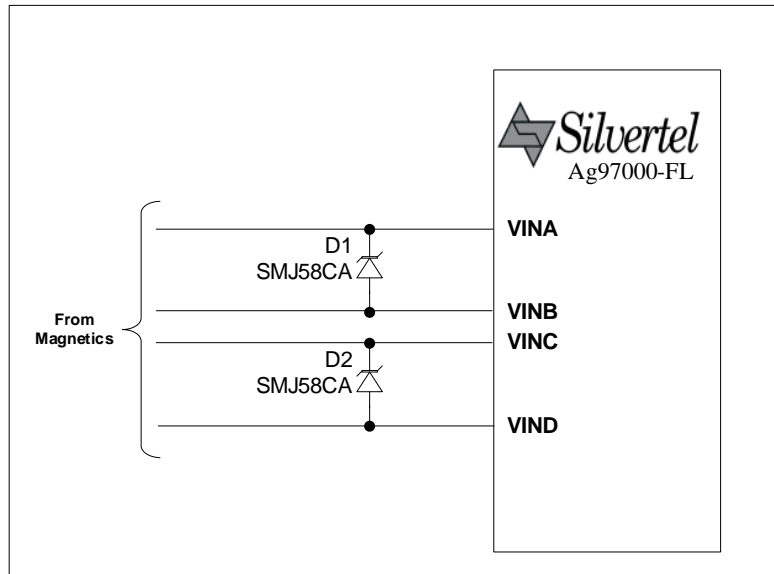

Figure 7: Input Protection

5.2 Output Back Feed Protection

If an external or auxiliary supply is to be used, it is essential that a blocking diode is present to prevent voltage injection on to the output circuitry of the module. This may cause damage to the module. The back feed protection is required even if the external voltage is present only while the module remains unpowered.

5.3 Output Short Circuit Protection

The Ag97000-FL has over-current protection to prevent the module from becoming damaged in the event of a short circuit event. If an over current event occurs the Ag97000 will disable the output, the Ag97000 will then test the current draw approximately every 400 milliseconds until the cause of the over current is removed, after which, the power will be restored to the output.

5.4 Thermal Protection

The Ag97000-FL contains built in thermal protection to prevent the module becoming damaged in the event that it is operated beyond its temperature specification. When the Ag97000-FL has detected it is over temperature, the output will be disabled until the module has cooled sufficiently.

6 Isolation

To meet the safety isolation requirements of IEEE802.3 specification, a powered device must provide electrical isolation between all its accessible external connectors, including frame ground. In order to meet this requirement, the powered device should be subjected to and pass at least one of the following electrical strength tests of IEC 60950-1:2001 sub clause 6.2.1.

- a) 1500V_{rms} at 50-60Hz for 60 seconds
- b) 2250V_{dc} for 60 seconds or
- c) 1500V_{dc} impulse test 10 times in either polarity.

To assist in this the Ag97000-FL has been designed to meet and pass the 1500V_{dc} impulse test with no breakdown of insulation.

In order to maintain this isolation requirement, it is essential that the isolation barrier is not breached, see ANX-POE-Isolation-Barrier for more details.

7 EMC

The Ag97000 has been designed to pass EN55032 Class B, however the Ag97000 will only be one component within the system so we would always advise that provisions are put in place in case further noise reductions are needed. From our experience we would recommend an inexpensive but effective solution to reduce emissions as shown in Figure 8, for more details please see ANX-POE-EMI-Considerations.

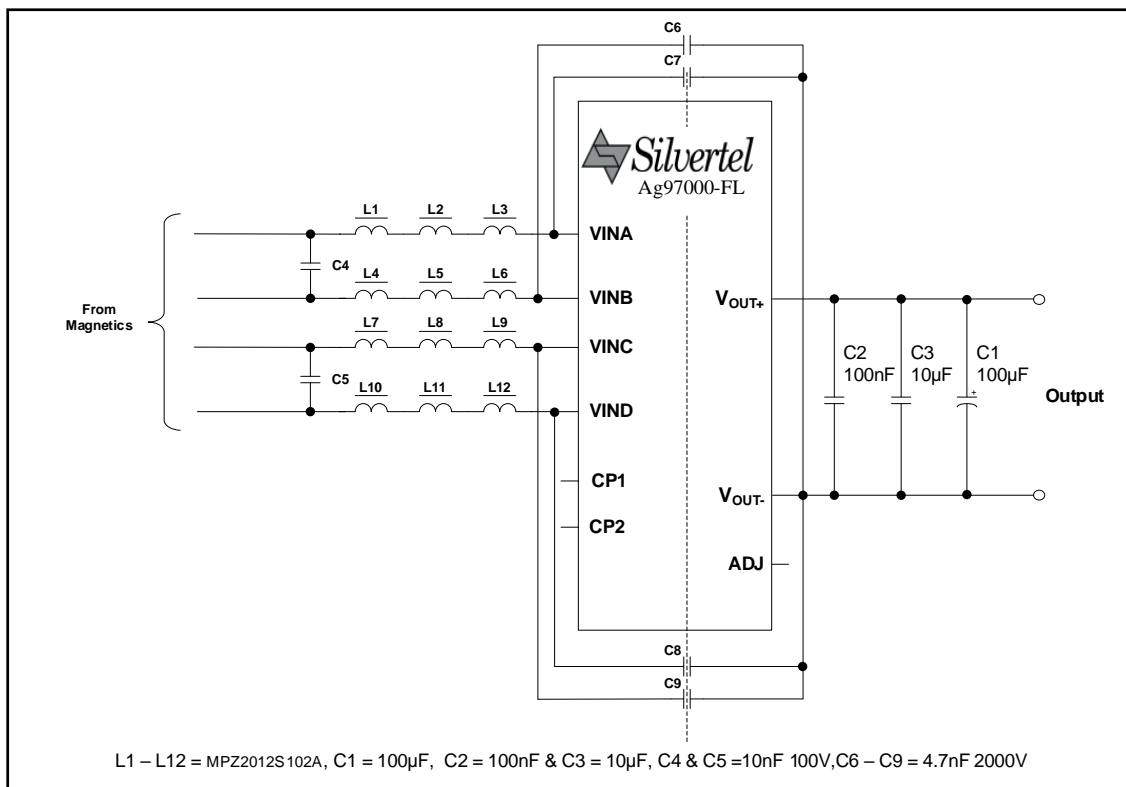

Figure 8: Typical Connection Diagram

8 Solderability

The Ag97000 is not suitable for a secondary reflow operation, and as such only wave soldering or hand soldering processes are recommended.

9 Electrical Characteristics

9.1 Absolute Maximum Ratings

	Parameter	Symbol	Min	Max	Units
1	DC Supply Voltage	V _{CC}	-0.3	60	V
2	Storage Temperature	T _s	-40	+100	°C
3	Moisture Sensitivity Level	MSL	-	1	-

Note : Exceeding the above ratings may cause permanent damage to the product. Functional operation under these conditions is not implied. Maximum ratings assume free airflow.

9.2 Recommended Operating Conditions

	Parameter	Symbol	Min	Typ	Max	Units	
1	Input Supply Voltage	V _{IN}	36	48	57	V	
2	Input Under Voltage Lockout	V _{ULOCK}		34.5		V	
3	Input Under Voltage Lockout	V _{ULOCK-Hsy}		1.2		V	
4	Operating Temperature	T _{OP}	-40	25	85	Ta / °C	
5	Output capacitance	Ag97005	C _{out}	47	100	470	μF
		Ag97012		47	100	470	
		Ag97024		47	100	330	

Note 1: At ≤ 50% load

9.3 DC Electrical Characteristics

	DC Characteristic		Sym	Min	Typ ¹	Max	Units	Comments
1	Nominal Output Voltage	Ag97005	V _{OUT+}		5		V	
		Ag97012		11.5	12	12.5		
		Ag97024		23.25	24	24.8		
2	Peak Output Power	Ag97005	P _{Max}		9		W	
		Ag97012			12			
		Ag97024			12			
3	Continuous Output Current Capability ²	Ag97005	I _{LOAD}		1800	2000 ⁵	mA	
		Ag97012			1000	1200 ⁵		
		Ag97024			500	600 ⁵		
4	Line Regulation		V _{LINE1}		0.04		%	
5	Load Regulation		V _{LOAD1}		0.1		%	
6	Ripple and Noise ³	Ag97005	V _{RN}		TBC		mVp-p	Full Load with 20MHz BW
		Ag97012			70			
		Ag97024			60			
7	Minimum Load		I _{Min}		0		mA	
8	MPS Output Load Requirement	Ag97005	I _{OUT_MPS}	70			mA	
		Ag97012		30				
		Ag97024		10				
9	Short-Circuit Duration		T _{SC}			∞	sec	
10	Peak System Efficiency ⁴	Ag97005	EFF		81.5		%	
		Ag97012			87.2			
		Ag97024			87.1			
11	Isolation Voltage (I/O)		V _{ISO}			1500	VPK	Impulse Test

Note 1: Typical figures are at 25°C with a nominal output voltage with 57V supply with a 100µF output capacitor fitted and are for design aid only. Not Guaranteed.

Note 2: Minimum 44V_{in} for maximum output at 25°C. Maximum output power may be limited by PSE.

Note 3: Measured with 100µF Electrolytic capacitor only. The output noise can be reduced further with external filtering in section 3.4.

Note 4: Efficiency measured between input and output pins of the module.

Note 5: With full down adjust

10 Package

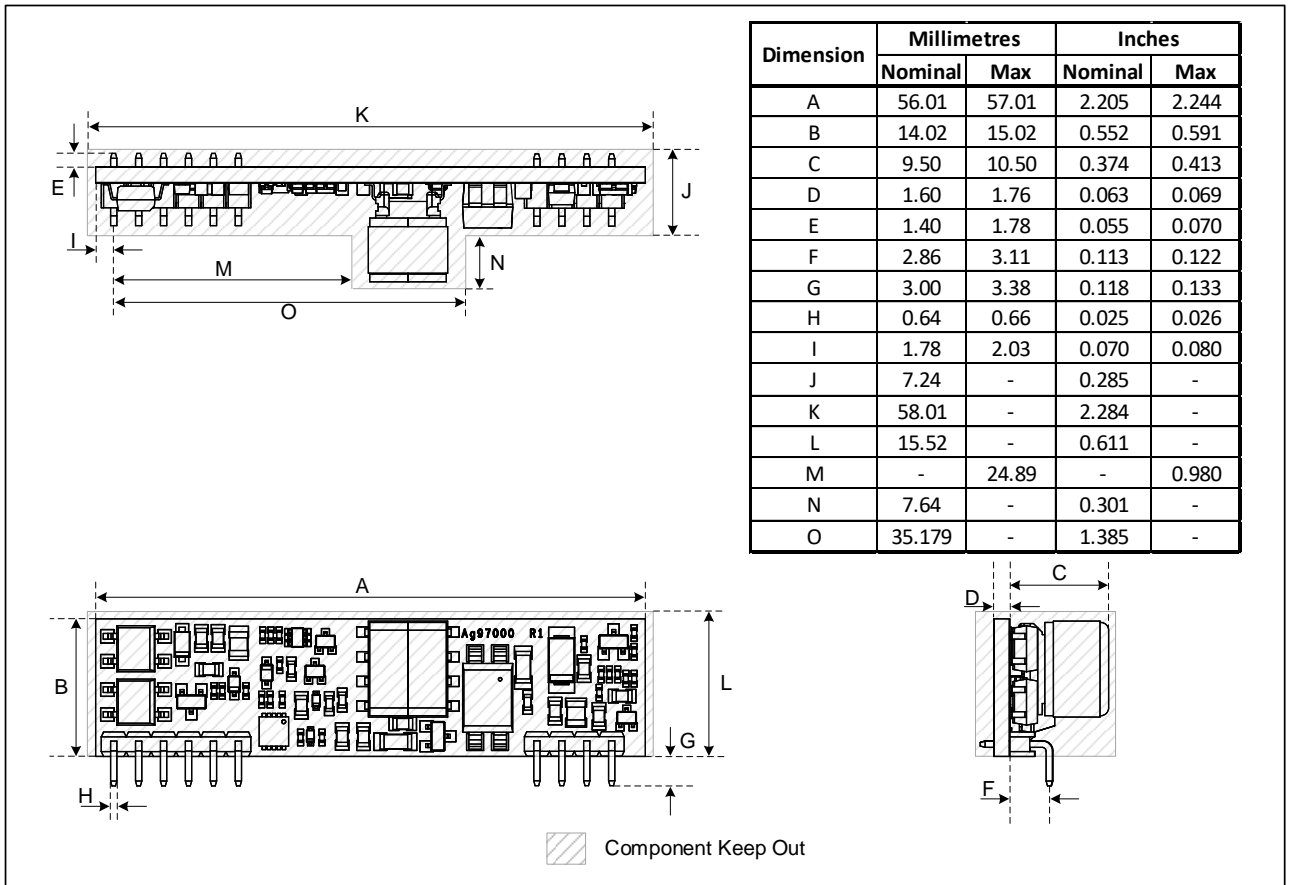

Figure 9: Package Dimensions

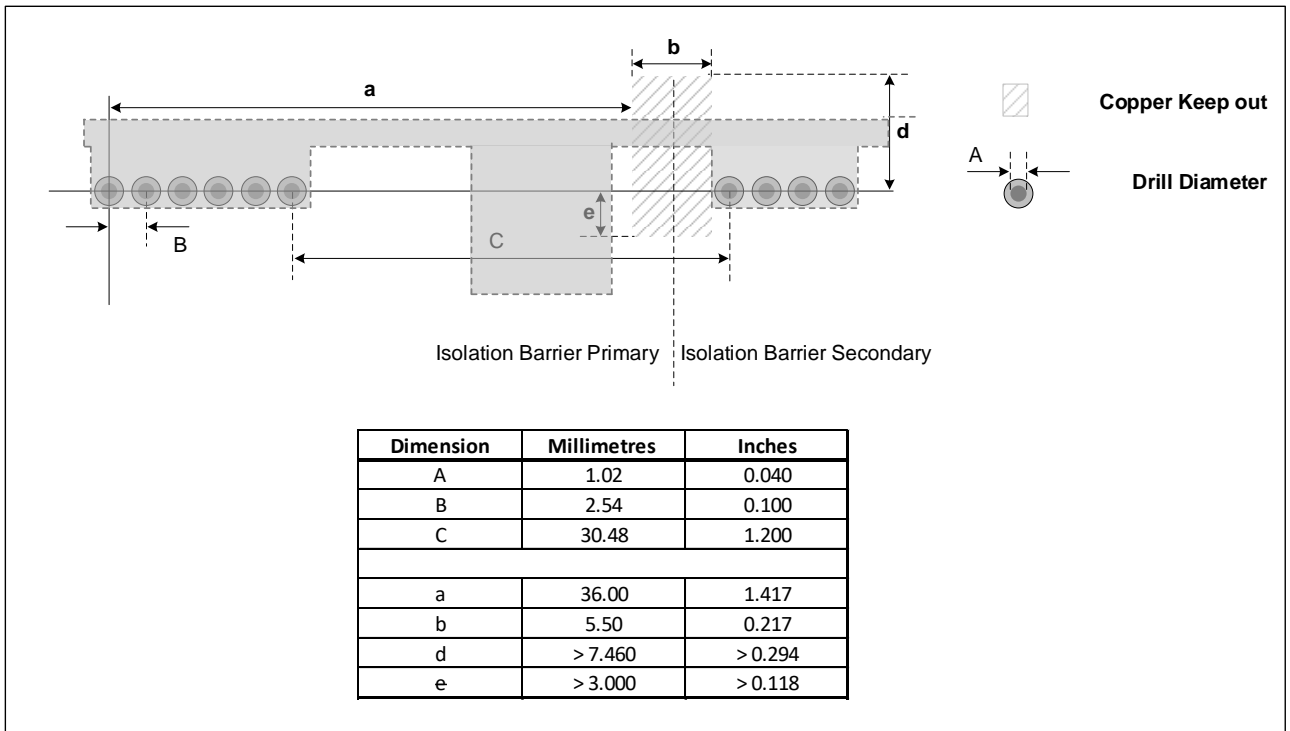
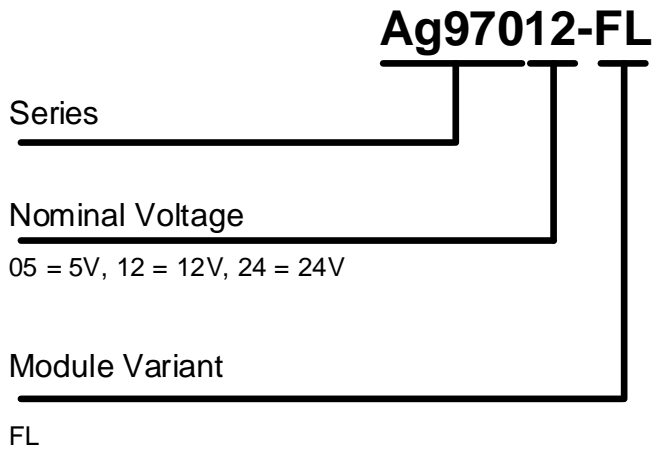

Figure 10: Land Pattern

11 Packaging

The default packing for the Ag97000 series is supplied in trays of 60.

12 Ordering Code



CODICO GmbH

Zwingenstraße 6-8, 2380 Perchtoldsdorf, Austria
 Telefon: +43 1 86 305-0, Fax: +43 1 86 305-5000
 e-mail: office@codico.com, www.codico.com
 FN 436940i, Landesgericht Wr. Neustadt

Zertifiziert nach ISO 9001:2015

Information published in this datasheet is believed to be correct and accurate. Silver Telecom assumes no liability for errors which may occur or for liability otherwise arising out of use of this information or infringement of patents which may occur as a result of such use. No license is granted by this document under patents owned by Silver Telecom or licensed from third parties by Silver Telecom. The products, their specification and information appearing in this document are subject to change by Silver Telecom without notice.
