

HCM1A1305V3

Automotive grade high current power inductor

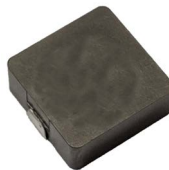

Photo is representative

Product features

- AEC-Q200
- High current carrying capacity
- Magnetically shielded, low EMI
- DC-DC converter applications up to 1 MHz
- Filtering applications up to Self resonant frequency (SRF) [See product specification table]
- Inductance range from 0.10 μ H to 33 μ H
- Current range from 4.5 A to 80 A
- 13.8 mm x 12.9 mm footprint surface mount package in a 5.0 mm height
- Alloy powder core material
- Moisture sensitivity level (MSL): 1

Applications

- Body electronics
 - Central body control module
 - Headlamps, tail lamps and interior lighting and LED lighting
 - Heating ventilation and air conditioning controllers (HVAC)
 - Doors, window lift and seat control
- Advanced driver assistance systems
 - Adaptive cruise control (ACC)
 - Automatic parking control
 - Collision avoidance system/ Car black box system
- Infotainment and cluster electronics
 - Audio subsystem: head unit and trunk amp
 - Digital instrument cluster
 - In-vehicle infotainment (IVI) and navigation
- Chassis and safety electronics
 - Airbag control unit
 - Electronic stability control system (ESC)
 - Electric parking brake
 - Electronic power steering (EPS)
- Engine and powertrain systems
 - Electric pumps, motor control and auxiliaries
 - Powertrain control module (PCU)/ Engine control unit (ECU)
 - Transmission Control Unit (TCU)

Environmental compliance and general specifications

- Storage temperature (component): -55 °C to +155 °C
- Operating temperature range: -55 °C to +155 °C (ambient plus self-temperature rise)



Product specifications

Part number ⁶	OCL ¹ (μ H) $\pm 20\%$	FLL ² (μ H) minimum	I _{rms} ³ (A)	I _{sat} ⁴ (A)	DCR (m Ω) typical @ +20 °C	DCR (m Ω) maximum @ +20 °C	SRF (MHz) typical	K-factor ⁵
HCM1A1305V3-R10-R	0.10	0.064	43	80	0.33	0.59	234	1190
HCM1A1305V3-R22-R	0.22	0.14	48	60	0.53	0.61	107	648
HCM1A1305V3-R33-R	0.33	0.21	46	50	0.59	0.69	70	497
HCM1A1305V3-R47-R	0.47	0.30	44	50	0.70	0.85	58	367
HCM1A1305V3-R56-R	0.56	0.36	29.5	50	1.15	1.33	57	239
HCM1A1305V3-R68-R	0.68	0.44	30	45	1.15	1.33	46	239
HCM1A1305V3-R82-R	0.82	0.52	27	36	1.40	1.61	45	366
HCM1A1305V3-1R0-R	1.0	0.64	24	35	1.78	2.05	40	277
HCM1A1305V3-1R5-R	1.5	0.96	19	27	2.60	3.0	30	165
HCM1A1305V3-1R8-R	1.8	1.15	17	26	3.25	3.74	30	182
HCM1A1305V3-2R2-R	2.2	1.41	15	25	4.04	4.65	25	144
HCM1A1305V3-3R3-R	3.3	2.11	12	19	5.75	9.20	16	146
HCM1A1305V3-4R7-R	4.7	3.01	11	18	8.15	9.38	13	105
HCM1A1305V3-5R6-R	5.6	3.58	10	17	11	12.7	11	87
HCM1A1305V3-6R0-R	6.0	3.84	9.7	16	11	12.7	11	100
HCM1A1305V3-6R8-R	6.8	4.35	9.5	15	12.1	14	11	111
HCM1A1305V3-7R8-R	7.8	4.99	7.6	15	15.04	17.3	10	79
HCM1A1305V3-8R2-R	8.2	5.25	7.5	13	16	18.5	9.0	65
HCM1A1305V3-100-R	10	6.40	7.5	13	18.17	20.9	8.0	72
HCM1A1305V3-120-R	12	7.68	7.0	9.0	19.5	23	6.0	117
HCM1A1305V3-150-R	15	9.60	6.5	9.5	23.5	27.1	6.0	51
HCM1A1305V3-220-R	22	14.1	5.0	7.0	34.74	40	5.0	39
HCM1A1305V3-330-R	33	21.1	4.5	5.2	49.2	58	3.0	39

- Open circuit inductance (OCL) test parameters: 100 kHz, 0.25 Vrms, 0.0 Adc, +25 °C
- Full load inductance (FLL) test parameters: 100 kHz, 0.25 Vrms, Isat, +25 °C
- Irms: DC current for an approximate temperature rise of 30 °C without core loss. Derating is necessary for AC currents. PCB layout, trace thickness and width, air-flow, and proximity of other heat generating components will affect the temperature rise. It is recommended that the temperature of the part not exceed +155 °C under worst case operating conditions verified in the end application.

- Isat: Peak current for approximately 20% rolloff @ +25 °C
- K-factor: Used to determine Bp-p for core loss (see graph). $Bp-p = K * L * \Delta I$. Bp-p: (Gauss), K: (K-factor from table), L: (Inductance in μ H), ΔI (Peak to peak ripple current in Amps).
- Part Number Definition: HCM1A1305V3-xxx-R
 HCM1A1305V3= Product code and size
 xxx= Inductance value in μ H, R= decimal point, if no R is present last digit indicates number of zeros
 -R = RoHS compliant

Dimensions- (mm)

Recommended pad layout

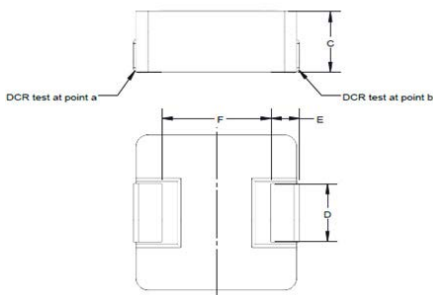
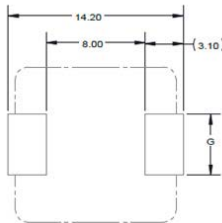
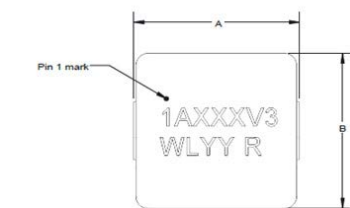

Schematic

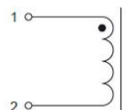

Part number	A	B	C	D	E	F	G
HCM1A1305V3-R	13.45 ± 0.35	12.6 ± 0.3	5.0 maximum	4.4 ± 0.3 (R10 to R47) 3.68 ± 0.3 (R56 to 2R2) 4.7 ± 0.3 (3R3 to 330)	2.3 ± 0.35	8.85 typ.	4.95 typ. (R10 to R47) 4.0 typ. (R56 to 2R2) 5.3 typ. (3R3 to 330)

Part marking: Pin 1 indicator dot, 1AxxxV3 xxx= inductance value in μ H, R= decimal point, if no R is present then last digit is the number of zeros, wlyy R= Lot code
 All soldering surfaces to be coplanar within 0.1 millimeters
 Tolerances are ± 0.3 millimeters unless stated otherwise
 DCR measured from point "a" to point "b"
 Traces or vias underneath the inductor is not recommended

Packaging information (mm)

Drawing not to scale

Supplied in tape and reel packaging, 250 parts per 13" diameter reel

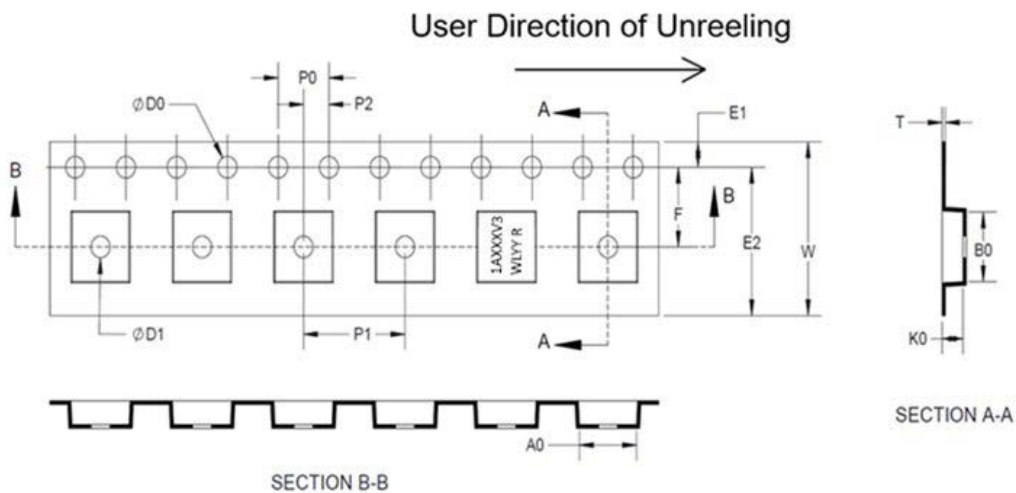

Dimension	Value
$W \pm 0.30$	24.0
$F \pm 0.10$	11.5
$E1 \pm 0.10$	1.75
$E2$ Min	22.25
$P0 \pm 0.10$	4.0
$P1 \pm 0.10$	16.0
$P2 \pm 0.10$	2.0
$D0 +0.10/-0$	1.5
$D1 +0.10/-0$	1.5
$A0$	13.4 ± 0.10
$B0$	14.4 ± 0.10
$K0$	5.4 ± 0.15
T	0.5 ± 0.05

Core loss vs. Bp-p

HCM1A1305V3-R10-R

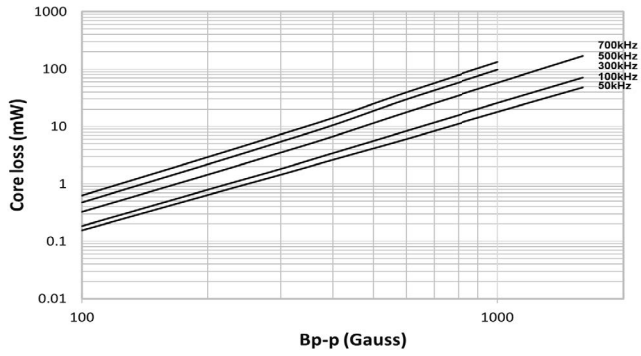

HCM1A1305V3-R22-R

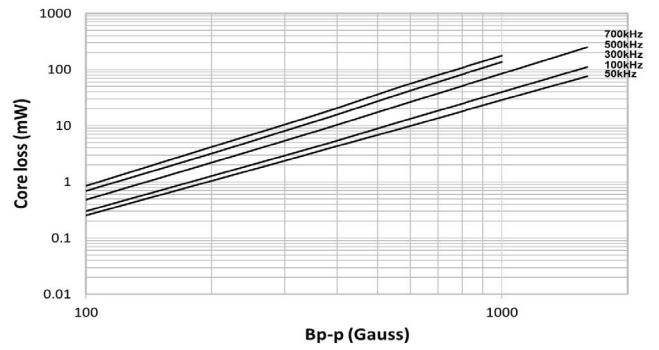

HCM1A1305V3-R33-R

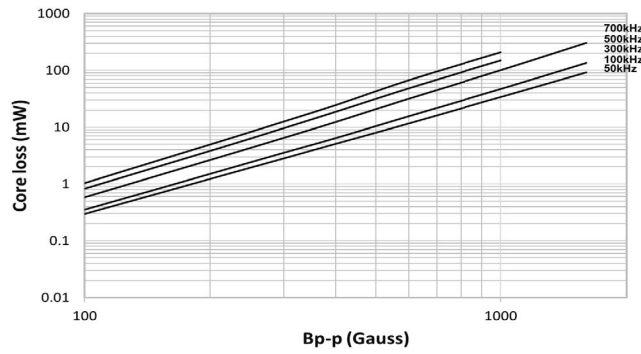

HCM1A1305V3-R47-R

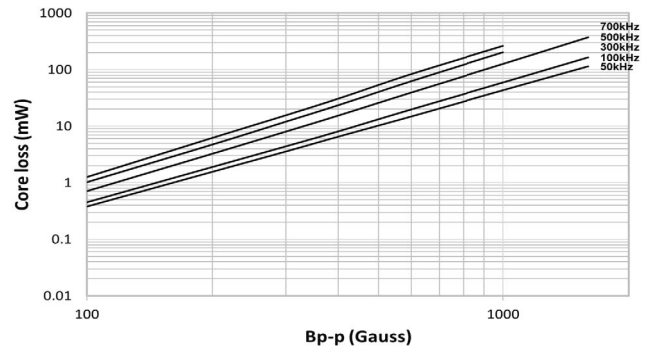

HCM1A1305V3-R56-R

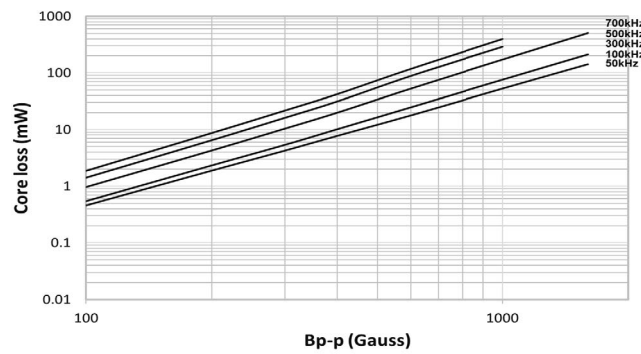

HCM1A1305V3-R68-R

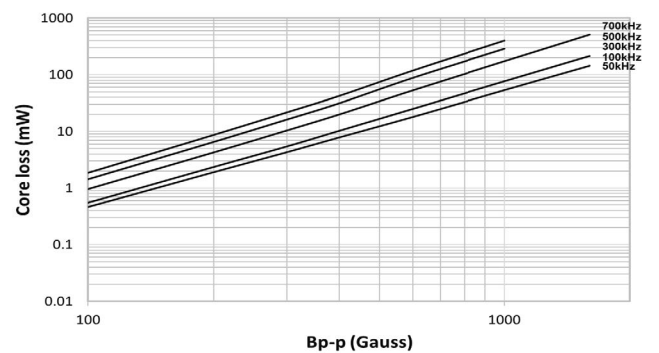

Core loss vs. Bp-p

HCM1A1305V3-R82-R

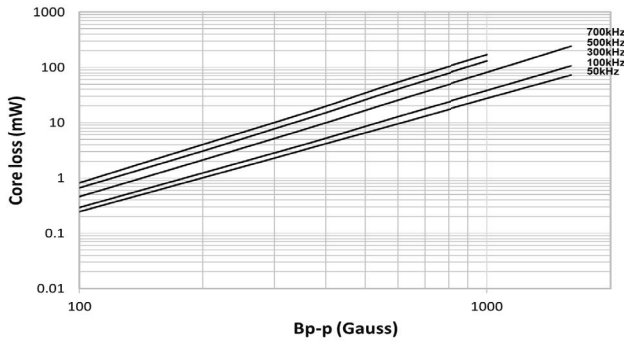

HCM1A1305V3-1R0-R

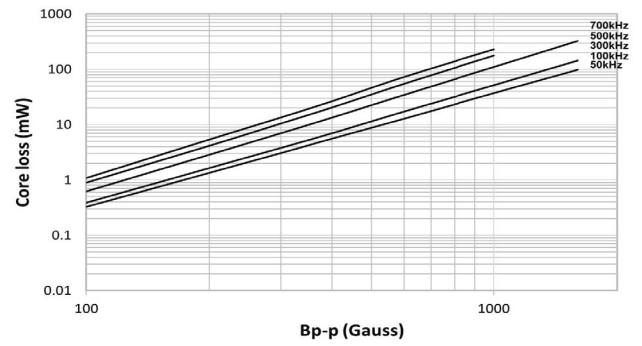

HCM1A1305V3-1R5-R

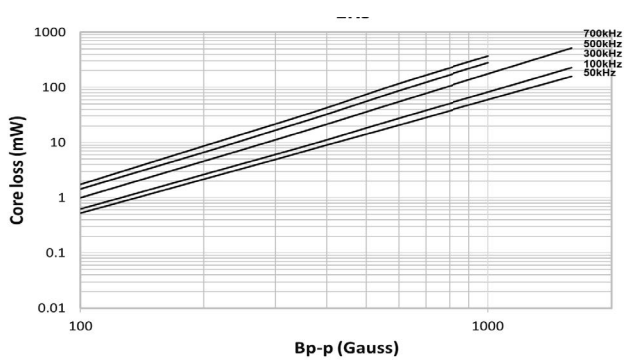

HCM1A1305V3-1R8-R

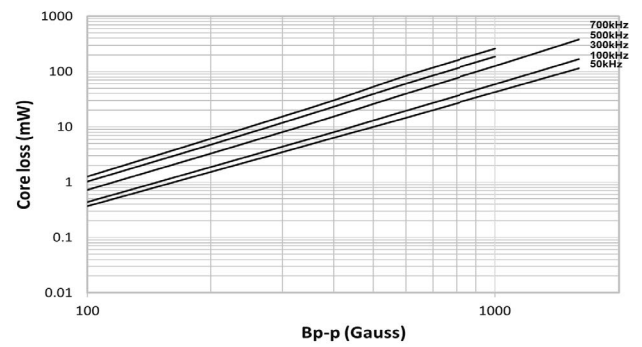

HCM1A1305V3-2R2-R

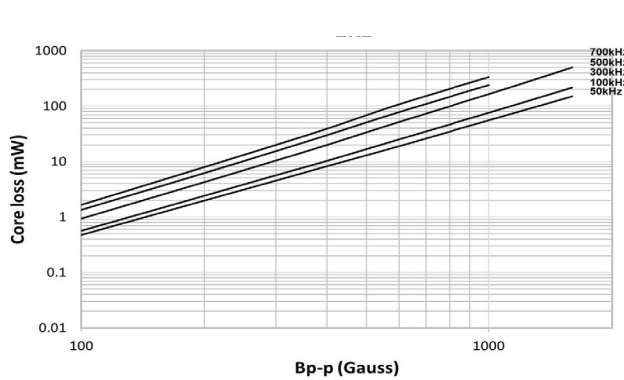

HCM1A1305V3-3R3-R

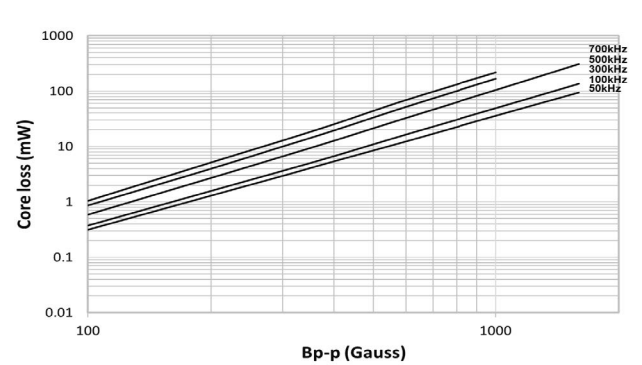

Core loss vs. Bp-p

HCM1A1305V3-4R7-R

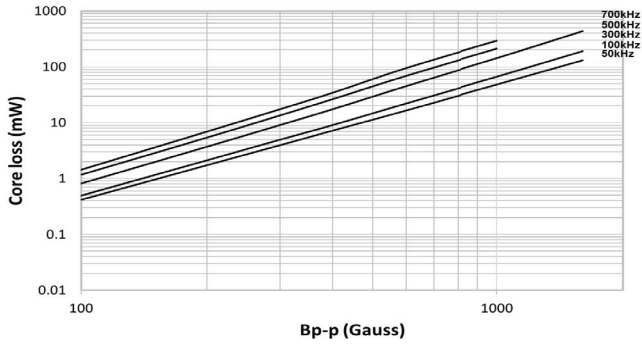

HCM1A1305V3-5R6-R

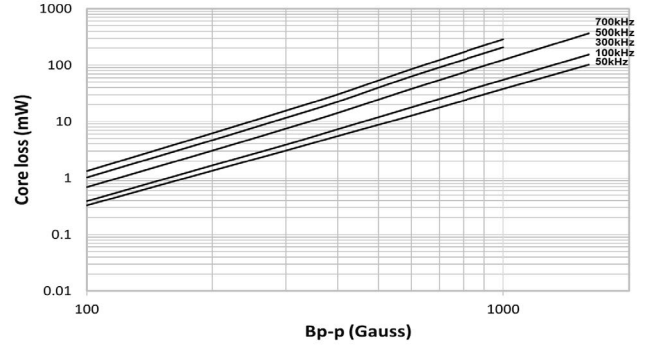

HCM1A1305V3-6R0-R

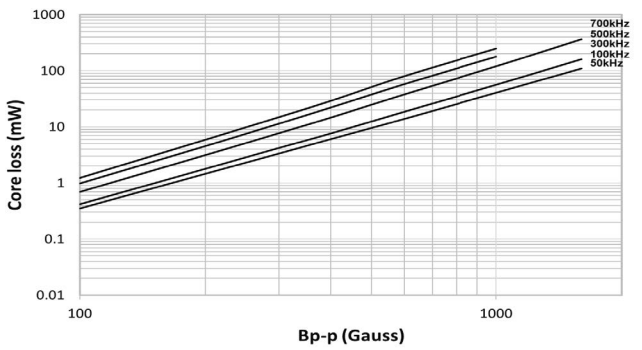

HCM1A1305V3-6R8-R

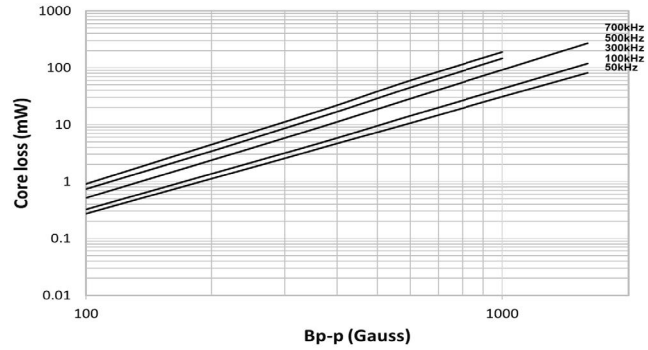

HCM1A1305V3-7R8-R

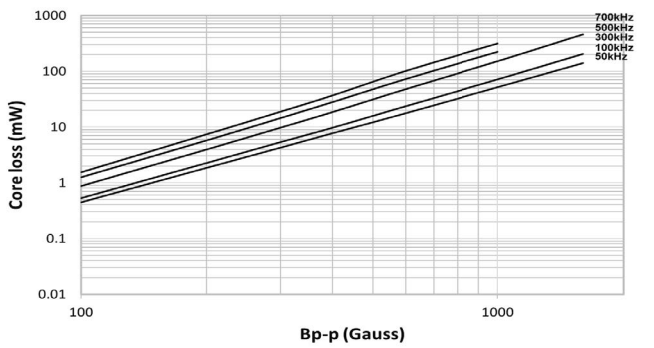

HCM1A1305V3-8R2-R

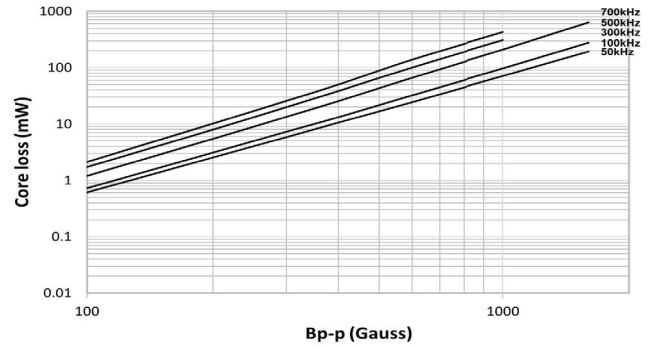

Core loss vs. Bp-p

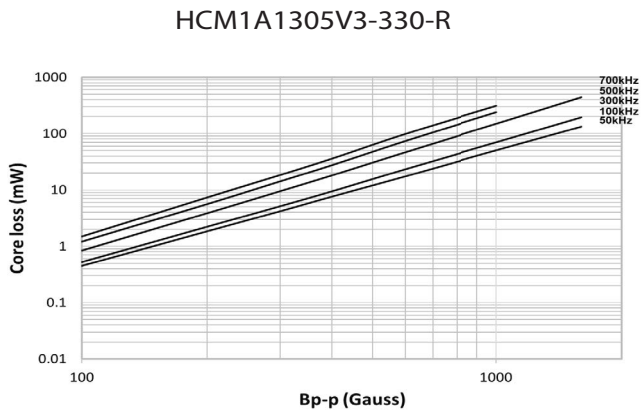
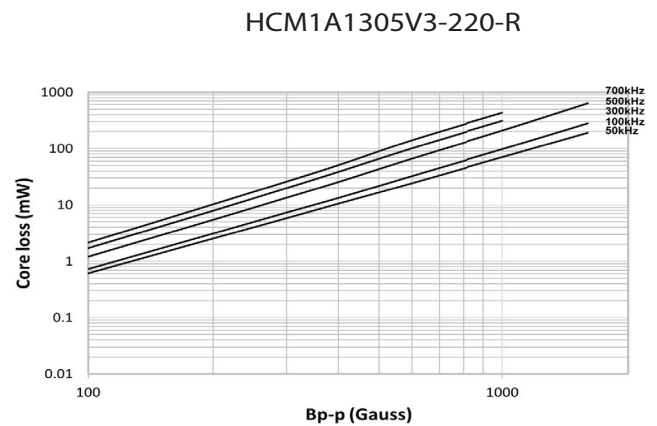
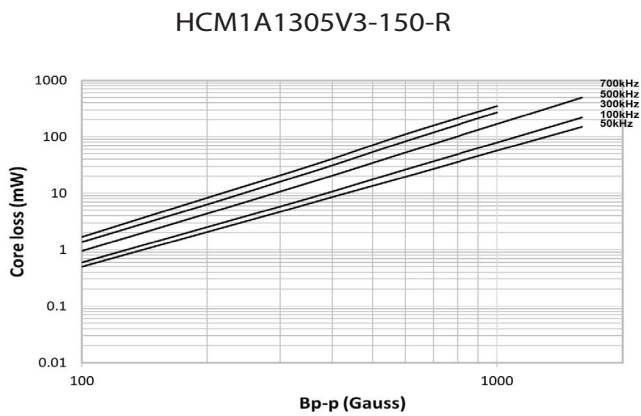
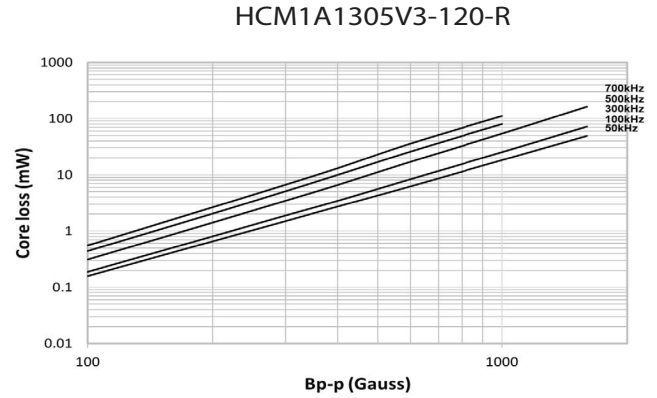
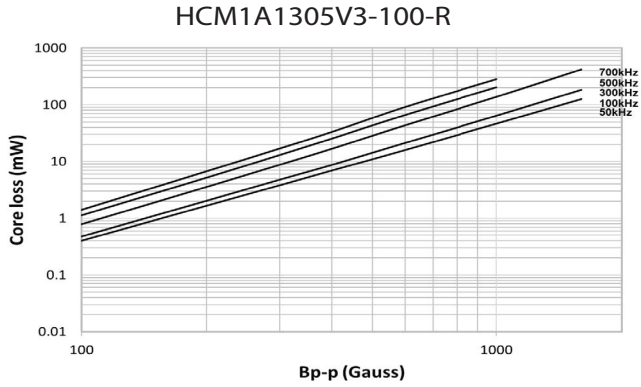

Inductance and temperature rise vs. I_{dc}

HCM1A1305V3-R10-R

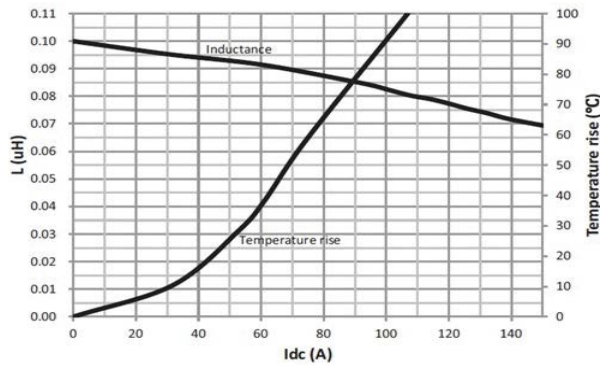

HCM1A1305V3-R22-R

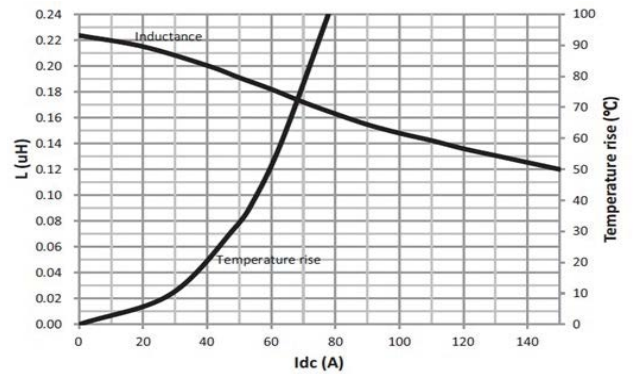

HCM1A1305V3-R33-R

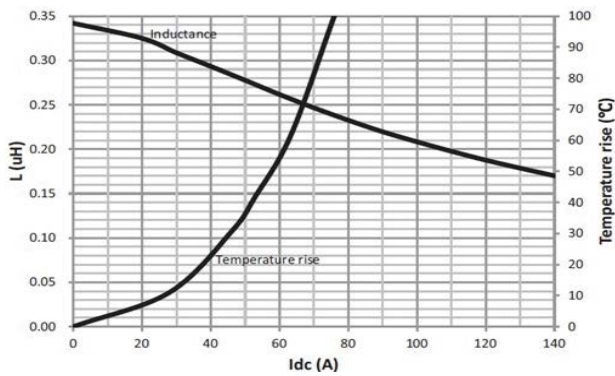

HCM1A1305V3-R47-R

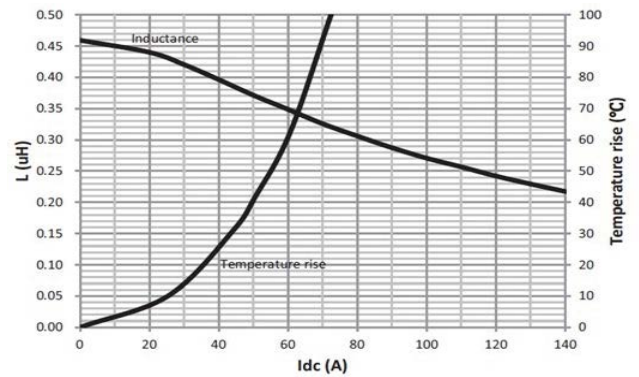

HCM1A1305V3-R56-R

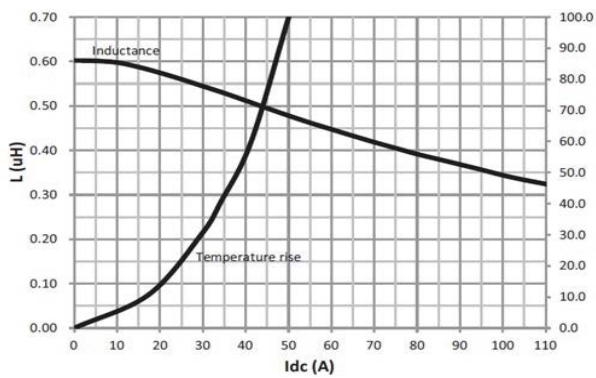

HCM1A1305V3-R68-R

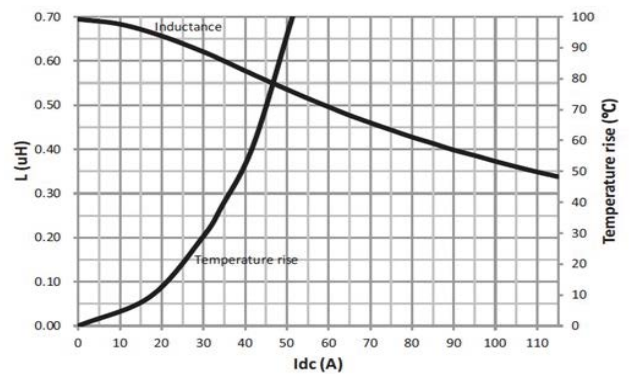

Inductance and temperature rise vs. I_{dc}

HCM1A1305V3-R82-R

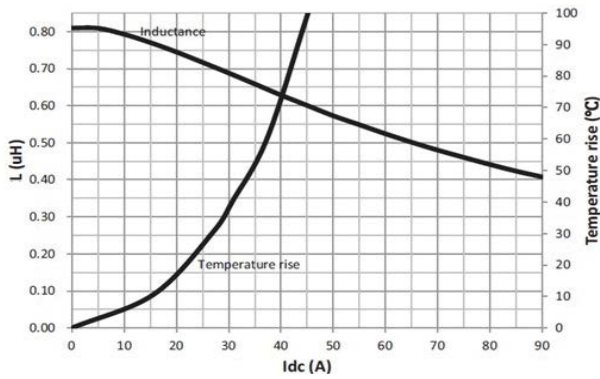

HCM1A1305V3-1R0-R

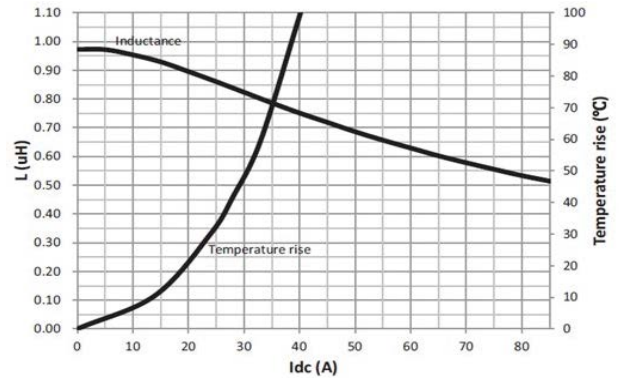

HCM1A1305V3-1R5-R

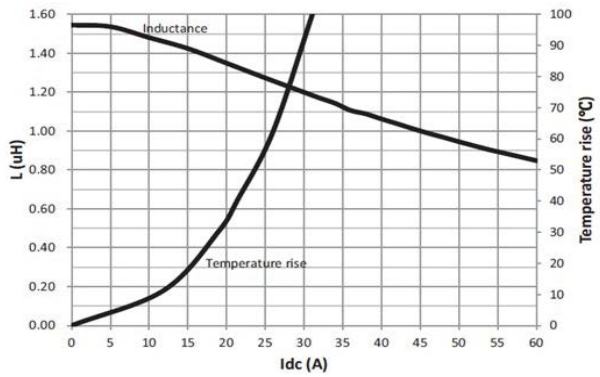

HCM1A1305V3-1R8-R

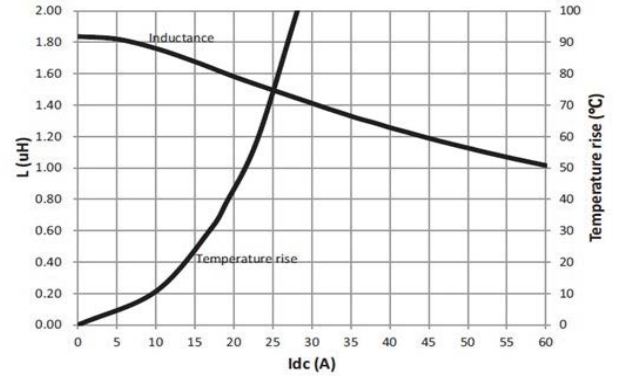

HCM1A1305V3-2R2-R

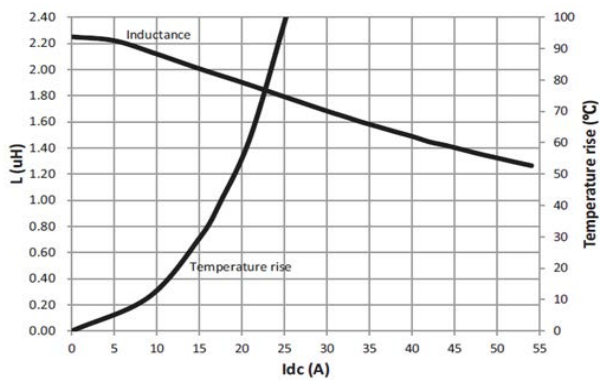

HCM1A1305V3-3R3-R

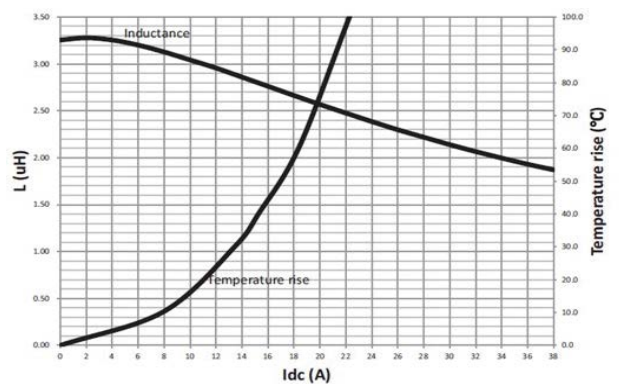

Inductance and temperature rise vs. I_{dc}

HCM1A1305V3-4R7-R

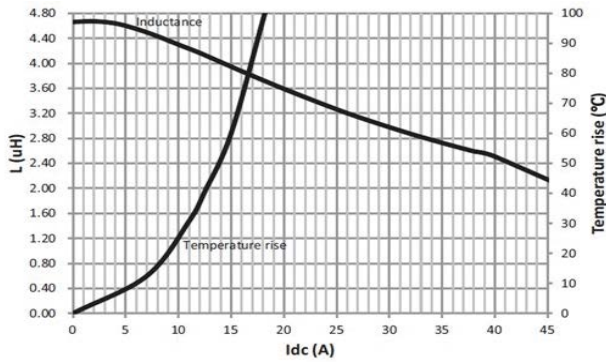

HCM1A1305V3-5R6-R

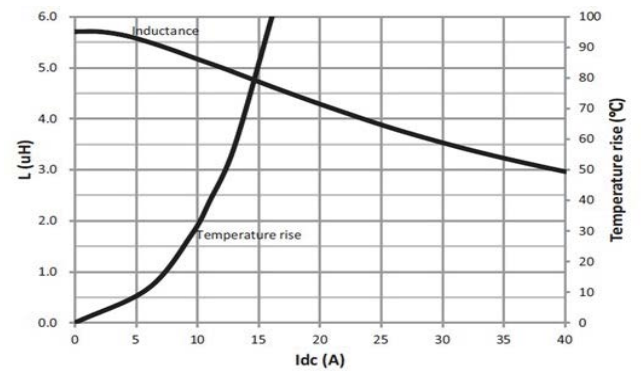

HCM1A1305V3-6R0-R

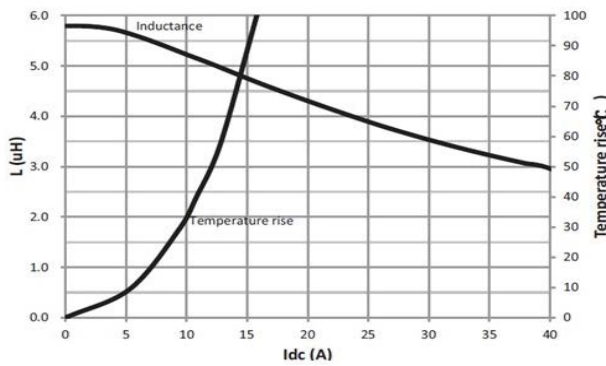

HCM1A1305V3-6R8-R

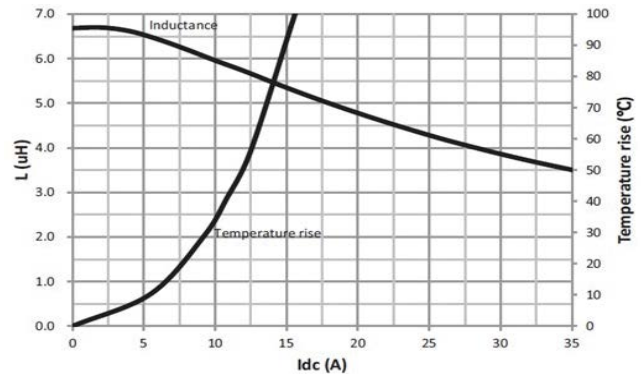

HCM1A1305V3-7R8-R

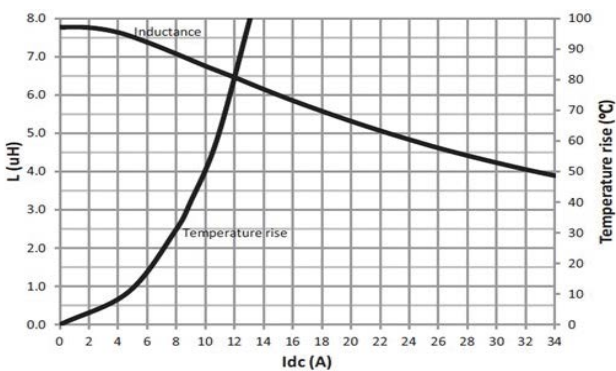

HCM1A1305V3-8R2-R

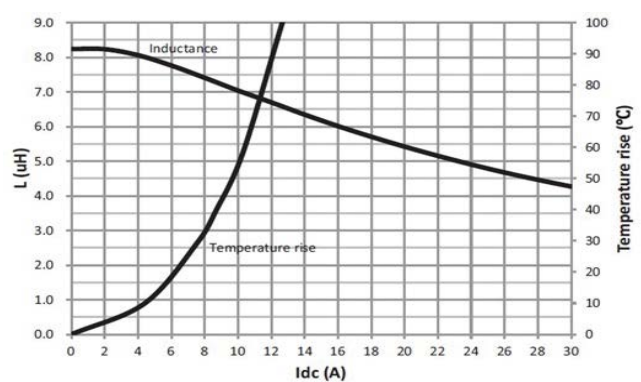

Inductance and temperature rise vs. I_{dc}

HCM1A1305V3-100-R

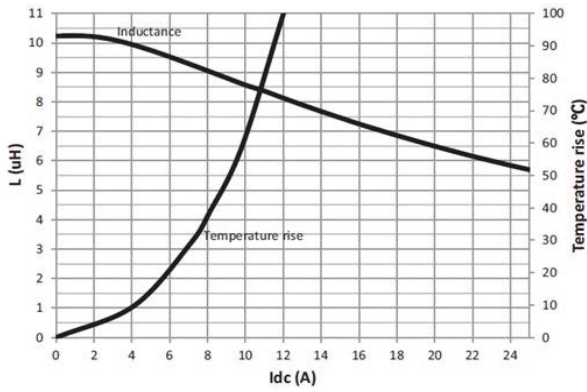

HCM1A1305V3-120-R

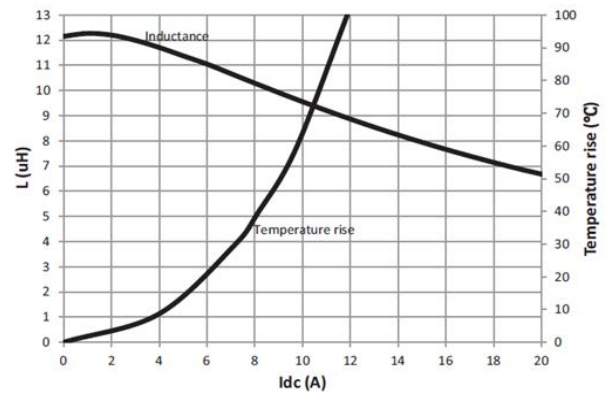

HCM1A1305V3-150-R

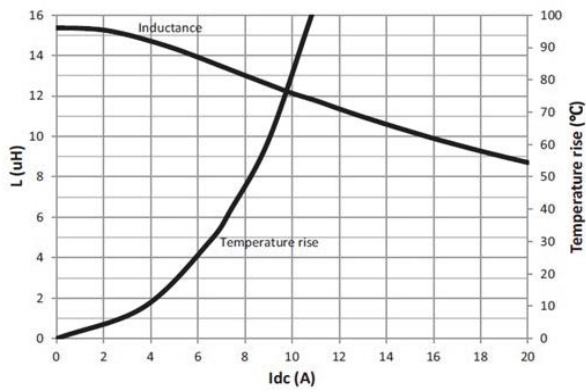

HCM1A1305V3-220-R

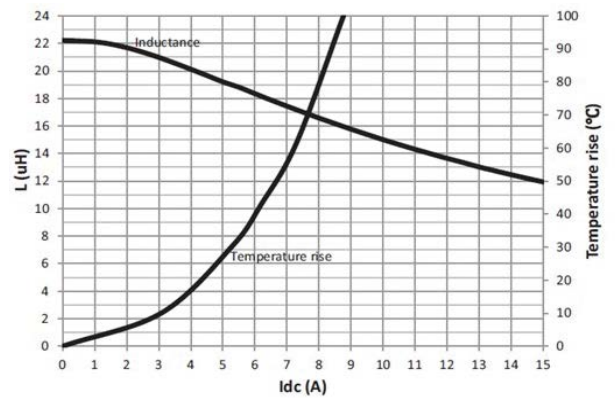

HCM1A1305V3-330-R

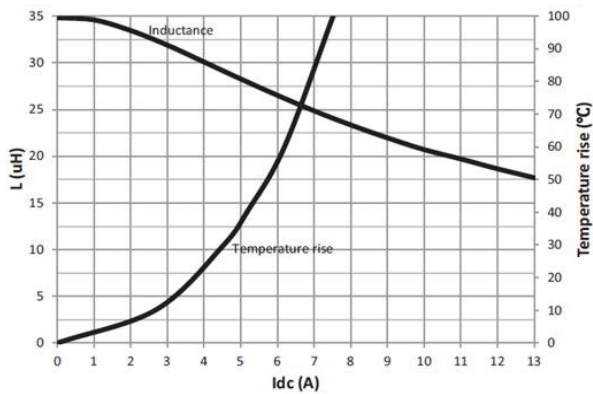

Inductance and impedance vs. frequency

HCM1A1305V3-R10-R

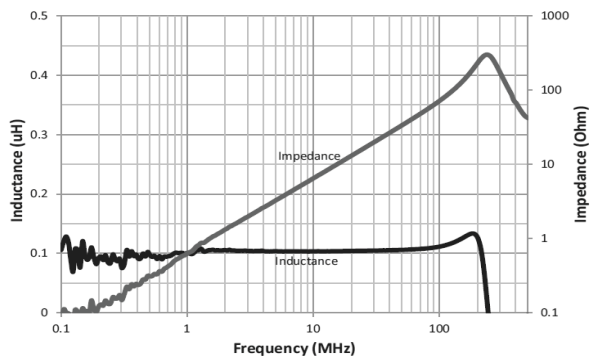

HCM1A1305V3-R22-R

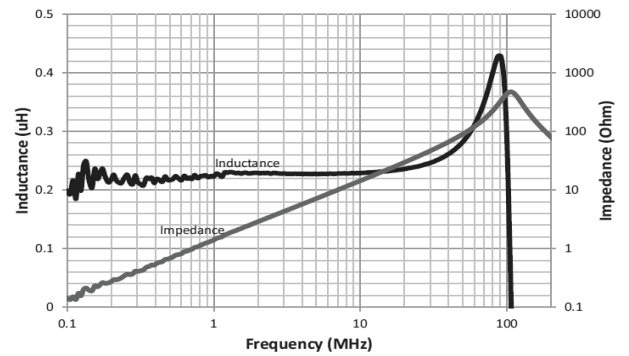

HCM1A1305V3-R33-R

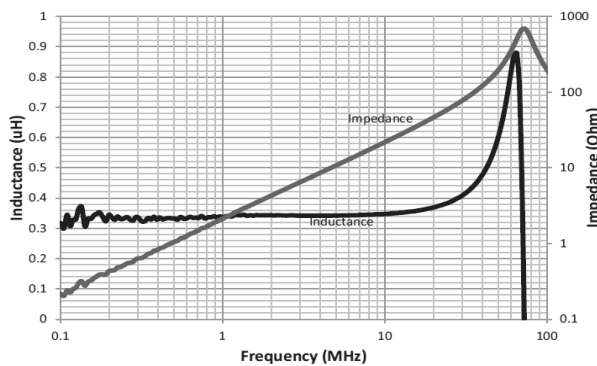

HCM1A1305V3-R47-R

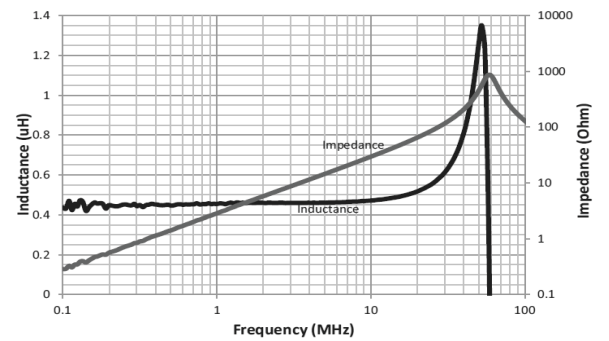

HCM1A1305V3-R56-R

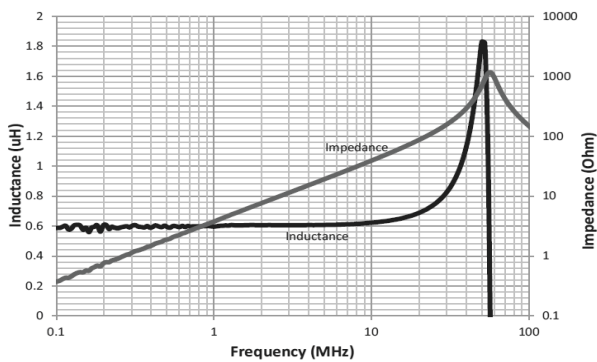

HCM1A1305V3-R68-R

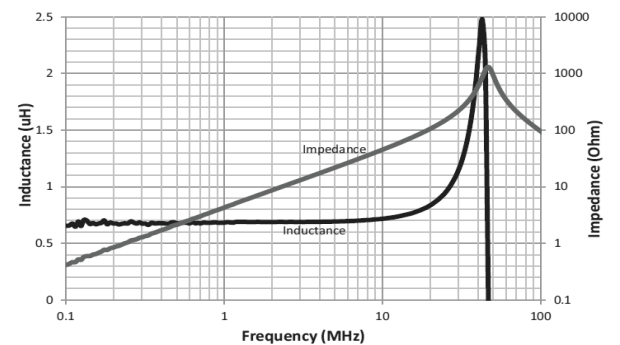

Inductance and impedance vs frequency

HCM1A1305V3-R82-R

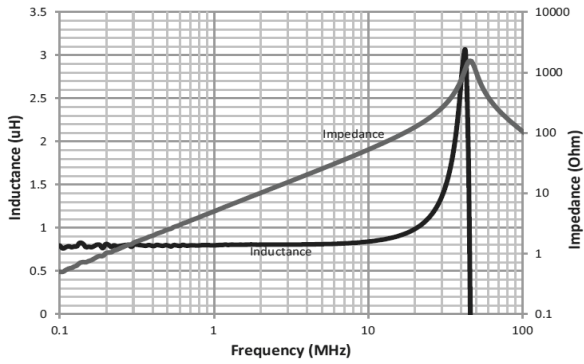

HCM1A1305V3-1R0-R

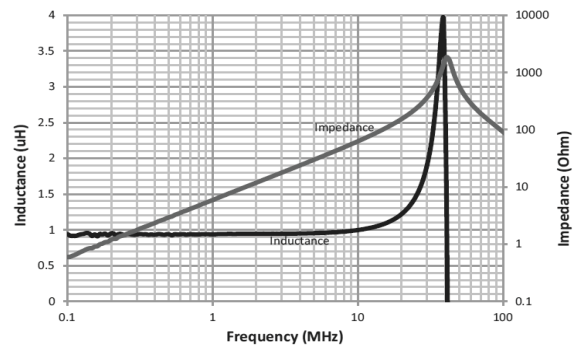

HCM1A1305V3-1R5-R

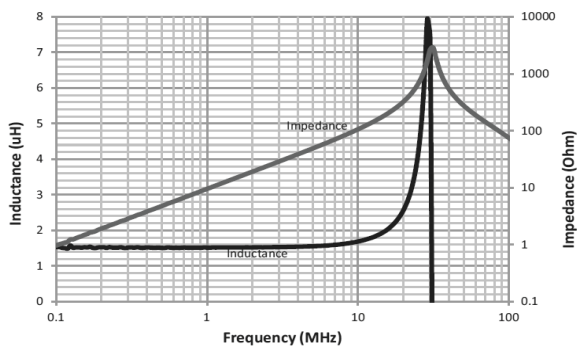

HCM1A1305V3-1R8-R

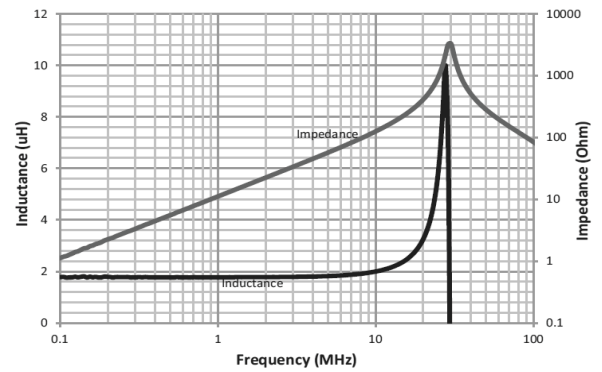

HCM1A1305V3-2R2-R

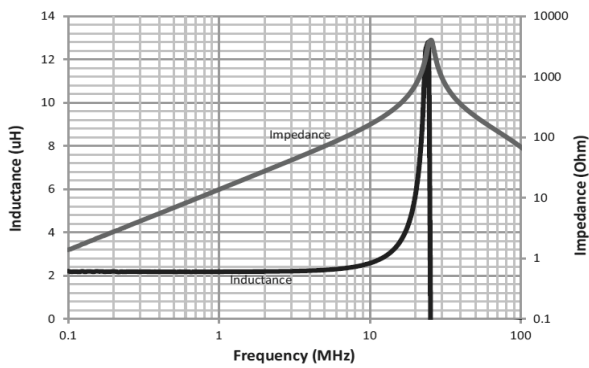

HCM1A1305V3-3R3-R

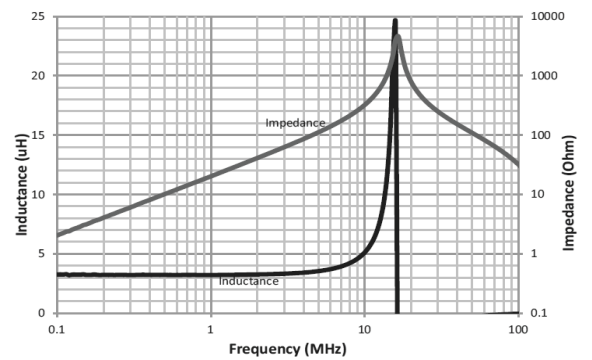

Inductance and impedance vs frequency

HCM1A1305V3-4R7-R

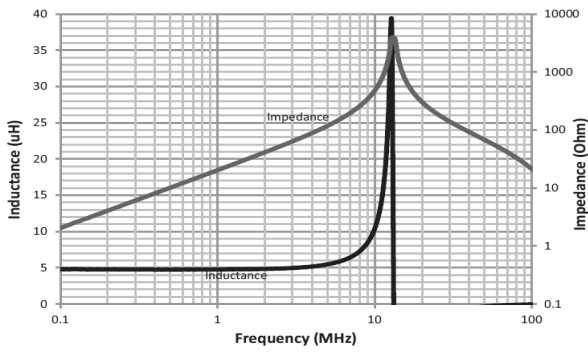

HCM1A1305V3-5R6-R

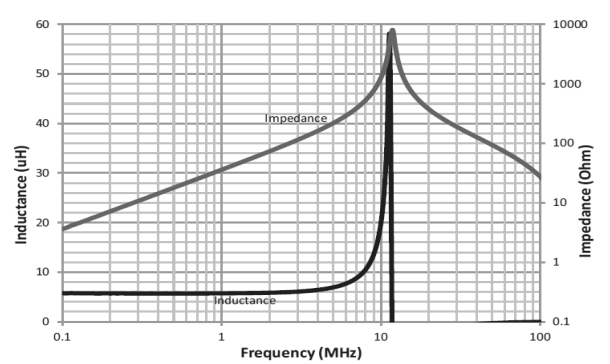

HCM1A1305V3-6R0-R

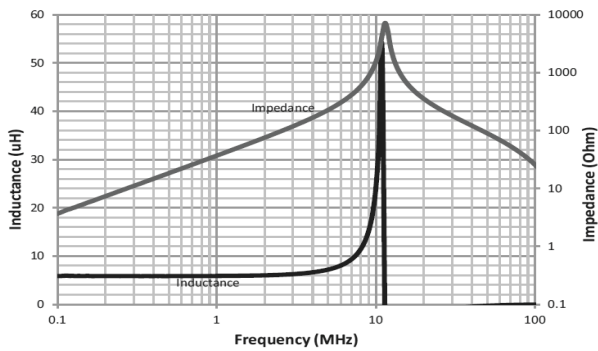

HCM1A1305V3-6R8-R

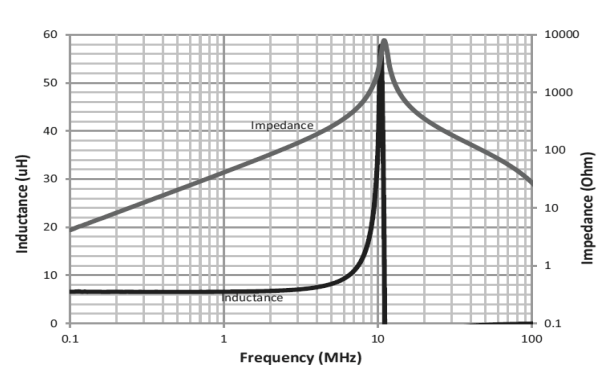

HCM1A1305V3-7R8-R

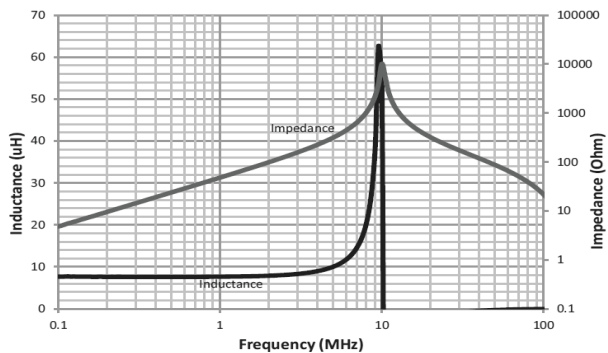

HCM1A1305V3-8R2-R

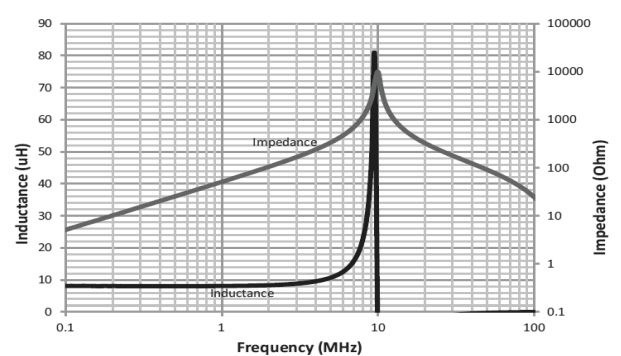

Inductance and impedance vs frequency

HCM1A1305V3-100-R

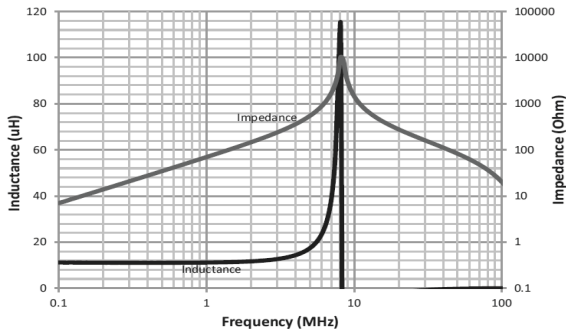

HCM1A1305V3-120-R

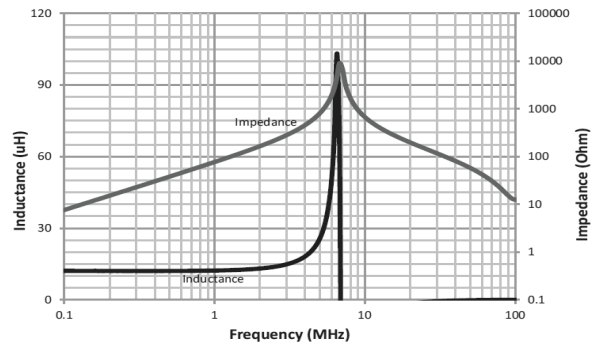

HCM1A1305V3-150-R

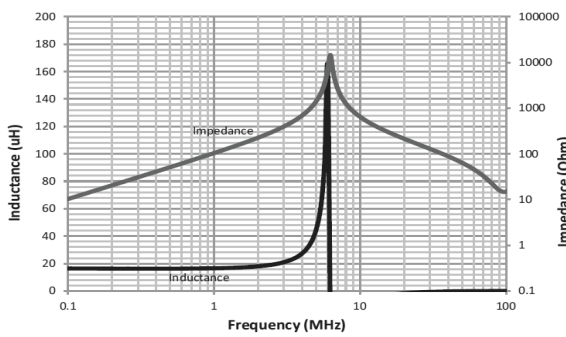

HCM1A1305V3-220-R

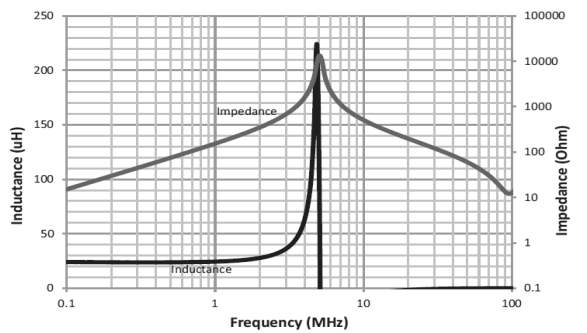

HCM1A1305V3-330-R

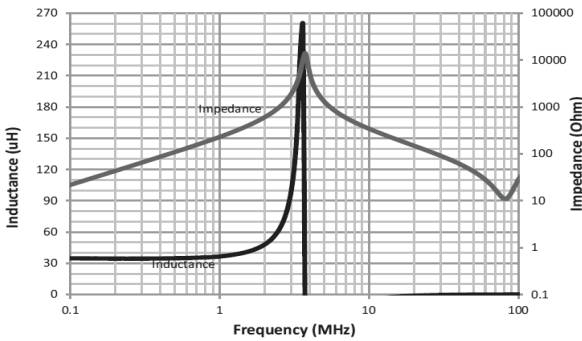

Solder reflow profile

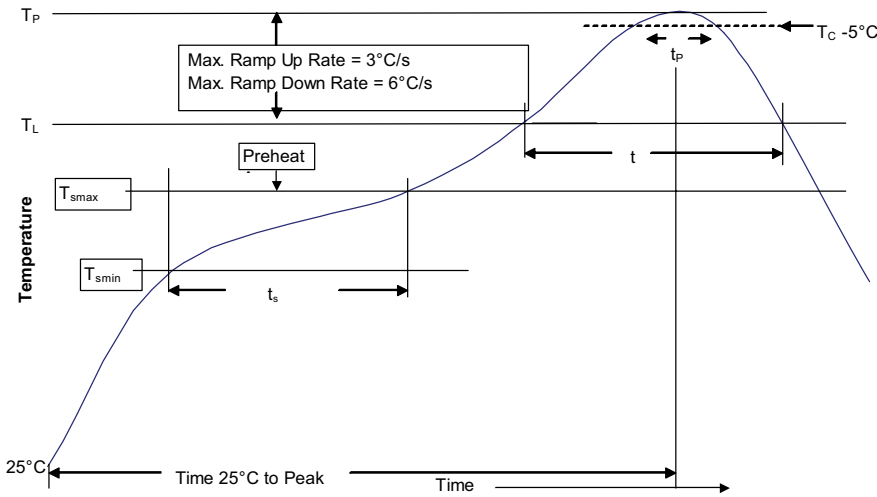

Table 1 - Standard SnPb solder (T_c)

Package thickness	Volume mm^3 <350	Volume mm^3 \geq 350
<2.5 mm	235 °C	220 °C
\geq 2.5 mm	220 °C	220 °C

Table 2 - Lead (Pb) free solder (T_c)

Package thickness	Volume mm^3 <350	Volume mm^3 350 - 2000	Volume mm^3 >2000
<1.6 mm	260 °C	260 °C	260 °C
1.6 – 2.5 mm	260 °C	250 °C	245 °C
>2.5 mm	250 °C	245 °C	245 °C

Reference J-STD-020

Profile feature	Standard SnPb solder	Lead (Pb) free solder
Preheat and soak		
• Temperature min. (T_{smin})	100 °C	150 °C
• Temperature max. (T_{smax})	150 °C	200 °C
• Time (T_{smin} to T_{smax}) (t_s)	60-120 seconds	60-120 seconds
Ramp up rate T_L to T_p	3 °C/ second max.	3 °C/ second max.
Liquidous temperature (T_L)	183 °C	217 °C
Time (t_L) maintained above T_L	60-150 seconds	60-150 seconds
Peak package body temperature (T_p)*	Table 1	Table 2
Time (t_p)* within 5 °C of the specified classification temperature (T_c)	20 seconds*	30 seconds*
Ramp-down rate (T_p to T_L)	6 °C/ second max.	6 °C/ second max.
Time 25 °C to peak temperature	6 minutes max.	8 minutes max.

* Tolerance for peak profile temperature (T_p) is defined as a supplier minimum and a user maximum.

Life Support Policy: Eaton does not authorize the use of any of its products for use in life support devices or systems without the express written approval of an officer of the Company. Life support systems are devices which support or sustain life, and whose failure to perform, when properly used in accordance with instructions for use provided in the labeling, can be reasonably expected to result in significant injury to the user.

Eaton reserves the right, without notice, to change design or construction of any products and to discontinue or limit distribution of any products. Eaton also reserves the right to change or update, without notice, any technical information contained in this bulletin.

Eaton
Electronics Division
1000 Eaton Boulevard
Cleveland, OH 44122
United States
Eaton.com/electronics

© 2024 Eaton
All Rights Reserved
Printed in USA
Publication No. ELX1488 BU-ELX22379
November 2024

Eaton is a registered trademark.
All other trademarks are property of their respective owners.

Follow us on social media to get the latest product and support information.

